

Technical Information

# MOBIREX MR 130i PRO



**Track-mounted impact crusher**

For use in natural stone and recycling

**MOBIREX PRO**

Series

## HIGHLIGHTS

- > Generously dimensioned double-deck prescreen with 3.5 yd<sup>2</sup> open screening surface
- > Fully hydraulic gap adjustment and overload system
- > Diesel-electric, connection to external power supply (optional)
- > Simple and intuitive SPECTIVE control concept
- > Powerful double-deck post screening unit, for use as a single-deck or double-deck screen

**MOBIREX MR 130i PRO mobile impact crusher**

The MOBIREX MR 130i PRO covers a very wide application range in natural stone and recycling. A positive feature of the plant is its all-electric drive concept with the option of an external power supply. CO<sub>2</sub>-free operation guarantees low energy consumption per ton of final product.



**TECHNICAL DATA MR 130i PRO**

Performance levels	
Feed capacity up to approx. (US t/h)	661
Production output with rubble up to approx. (US t/h)	496 <sup>1)</sup>
Production output with demolished concrete up to approx. (US t/h)	441 <sup>1)</sup>
Production output with limestone up to approx. (US t/h)	441 <sup>1)</sup>
Production output with milled asphalt up to approx. (US t/h)	243 <sup>2)</sup>
Feeding unit	
Max. feed size	41" x 26"
Feed height (with extension)	14' 8" (15' 11")
Hopper volume (with extension) (yd <sup>3</sup> )	6.5 (11.8)
Width x length (with extension)	7' 5" x 12' 2" (9' 10" x 12' 2")
Vibrating feeder	
Width x Length	44" x 8' 10"
Pre-screening	
Type	Double-deck heavy-piece screen
Width x Length	4' x 7' 10"
Side discharge conveyor rigid (optional)	
Width x Length	26" x 21' 8"
Discharge height approx.	11' 9"
Side discharge conveyor can be folded hydraulically (optional)	
Width x Length	26" x 19' 8"
Discharge height approx.	11' 2"
Crusher	
Impact crusher type	SHB 130 - 090
Crusher inlet width x height	52" x 36"
Crusher weight approx. (lbs)	37,500
Rotor diameter	47"
Crusher drive type, approx. (hp)	electric, 335
Adjustment of impact toggles	infinitely variable, fully hydraulic

Discharge chute	
Width x Length	57" x 8' 9"
Crusher discharge conveyor	
Width x Length	56" x 39' 8"
Discharge height approx.	14' 5"
Power supply unit	
Drive concept	diesel-electric
Drive output of Scania diesel engine (hp)	641
Generator (kVA)	550
Post screening unit (optional)	
Type	Double-deck screen
Width x length of upper deck approx.	5' 1" x 18' 1"
Width x length of lower deck approx.	5' 1" x 15' 5"
Side discharge conveyor, medium grain: Width x length approx.	26" x 22' 4"
Side discharge conveyor, medium grain: Discharge height approx.	11' 2"
Discharge height, fine grain conveyor approx.	12' 6"
Return conveyor: Width x length approx. (mm)	26" x 36' 9"
Transport dimensions without options	
Transport height approx.	12' 10"
Transport length approx.	68' 9"
Transport width approx.	11' 4"
Transport dimensions with post screening	
Transport length with screening unit approx.	76' 4"
Transport width with post screening unit approx.	11' 6"
Transport weight of screening unit approx. (lbs)	28,670 <sup>3)</sup>
Transport weight of basic plant approx. (lbs)	141,150
Transport weight max. configuration approx. (lbs)	183,000

<sup>1)</sup> for final grain size 0 - 2" with approx. 10 - 15 % oversize grain  
<sup>2)</sup> for final grain size 0 - 1" with approx. 10 - 15 % oversize grain  
<sup>3)</sup> double-deck post screening unit incl. two transfer conveyors and middle grain conveyor

OPERATING POSITION

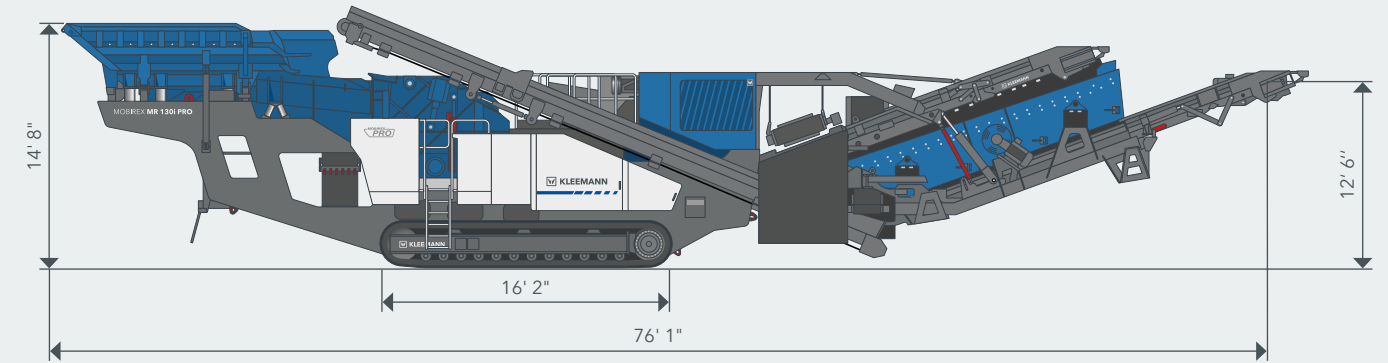

MATERIAL FLOW

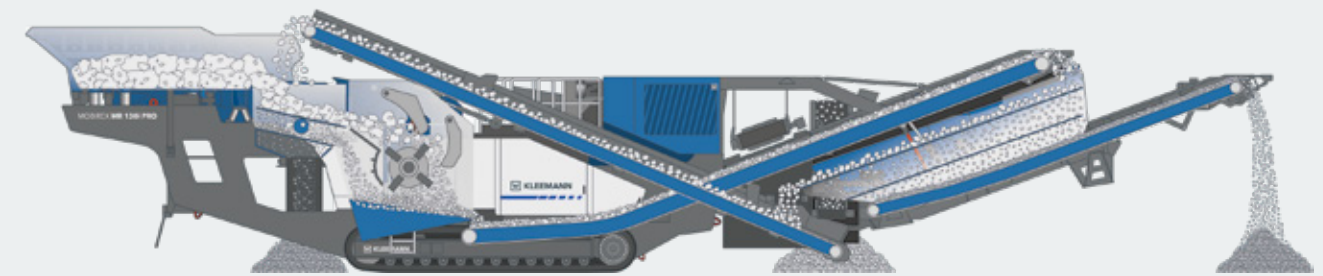

The MOBIREX MR 130i PRO excels with outstanding product quality and very high product output. The Continuous Feed System (CFS) guarantees continuous crusher utilisation. Thanks to the fully hydraulic crusher gap adjustment, machine parameters can be adapted quickly to the application. The overload system ensures effective

protection for the crusher and high plant availability even with non-homogeneous feed material. Thanks to the optional double-deck post screening unit, splitting of the target grain size into two separate material flows is possible. Lightweight material can also be removed from both material flows by means of wind sifters.

## STANDARD EQUIPMENT

- > Hydraulically-folding feed hopper, can be operated from ground
- > Frequency-controlled vibrating feeder
- > Frequency-controlled prescreen, stepless speed control
- > Side discharge conveyor, rigid, right; must be disassembled for transport
- > Continuous Feed System (CFS) for optimum crusher loading
- > Automatic crusher gap adjustment
- > Integrated overload protection
- > Rotor lock & turn device: system for securely turning and locking the rotor for maintenance tasks or clearing blockages
- > Swivel arm for changing rotor ledges
- > Co-vibrating crusher bypass flap for flexible change-over between side discharge and crusher bypass
- > External power supply for efficient mains operation
- > SPECTIVE control concept: menu-guided user interface, 12-inch control panel; telematics system for efficient fleet and service management
- > SPECTIVE CONNECT for displaying all important machine information directly on the smartphone
- > SPECTIVE remote control: wired and radio remote control incl. switch-off function for feeding unit
- > LED lighting
- > Water spray system for dust reduction

## OPTIONS

- > Hopper extension: hydraulically folding
- > Hopper filling aids for rearward loading: width of feed opening 10' 10"
- > Foldable side discharge conveyor, hydraulically foldable, configurable on both sides, remains on machine for transport
- > Reversible fan for dedusting the engine compartment
- > Raised engine air intake for reduced dust load
- > Power pack housing for damping noise sources, incl. sealing of the power pack base as noise and dust protection
- > Climate control packages: hot climate or cold climate package
- > Electromagnetic separator or permanent magnetic separator, suspended flexibly by chains, can be raised and lowered hydraulically
- > Reinforced conveyor belt for crusher discharge conveyor
- > Double-deck post screening unit, use as a single-deck or double-deck screen, production of up to two classified final grain sizes, incl. swivelling return conveyor
- > Return conveyor frequency converter for precise speed control
- > Middle grain conveyor, remains on the post screening unit for transport
- > Belt scale, available for crusher discharge conveyor, side discharge conveyor, middle grain conveyor and fine grain conveyor
- > Belt cover canvas, for rigid side discharge conveyor, crusher discharge conveyor and fine grain conveyor
- > Wind sifter for cleaning the oversize grain and medium grain to remove foreign and lightweight materials
- > Camera system for monitoring the feeding unit and the transfer point to the return conveyor from the ground, also available with radio extension, additional connection to SPECTIVE CONNECT
- > Small radio remote control with key operating functions
- > Quick Track for selecting machine operating mode quickly and easily, operation via radio remote control
- > Line coupling for interlinking with other KLEEMANN plants
- > Premium lighting

## WIRTGEN AMERICA

6030 Dana Way  
 Antioch, TN 37013  
 USA

T: +1 615 501 0600  
 M: info.america@wirtgen-group.com

[www.wirtgen-group.com/america](http://www.wirtgen-group.com/america)

