

Tracked Paver

SUPER 1300-3i



PERFECT IN ALL CLASSES

The right paver for every job

VÖGELE's seamless product range is considered unique in the industry. Whether a service road or a highway, an airfield or a race track, a new construction or a rehabilitation job, thick or thin, hot or cold - customers will find the right machine in our paver range for every paving task.



VÖGELE PRODUCT RANGE

MINI CLASS

- > Maximum paving width
10 ft. 6 in. (3.2 m)
- > Maximum laydown rate
275 tons/h (250 tonnes/h)

COMPACT CLASS

- > Maximum paving width
16 ft. 5 in. (5 m)
- > Maximum laydown rate
385 tons/h (350 tonnes/h)

UNIVERSAL CLASS

- > Maximum paving width
32 ft. 10 in. (10 m)
- > Maximum laydown rate
770 tons/h (700 tonnes/h)

HIGHWAY CLASS

- > Maximum paving width
42 ft 8 in (13 m)
- > Maximum laydown rate
1,540 tons/h (1,400 tonnes/h)

SPECIAL CLASS

- > SprayJet

HIGHLIGHT OVERVIEW

Perfectly equipped

DRIVE

01 Drive concept

> Powerful and economical drive concept with a modern diesel engine.

MATERIAL MANAGEMENT

02 Optimum mix feed

> Large material hopper with a capacity of 22,000 lbs. (10 tonnes) ensures optimum feeding with mix.

OPERATION

03 ErgoPlus 3 operating system

> ErgoPlus 3 operating system with numerous convenient and automatic functions.

04 AutoSet Basic

> AutoSet Basic function for quick, safe repositioning of the paver on the job site.

QUALITY

05 Niveltronic Plus - the System for Automated Grade and Slope Control

> Fully-integrated system perfectly matched to the machine technology of VÖGELE road pavers.
> Wide range of sensors for flexible use in all fields of application.
> User-friendly operation and monitoring of all Niveltronic Plus functions.

VERSATILITY

06 Wide range of applications

> Tracked Compact Class paver with a wide range of applications for paving widths up to 16 ft. 5 in. (5 m)

07 Extending Screed

> AB 340 Extending Screed ensures a perfect paving result.





01



02



03



04



05



06

COMPACT AND POWERFUL

The SUPER 1300-3i is a compact and highly versatile paver which, thanks to its small size, handles a wide range of most varied surfacing tasks including combined footpaths and cycle paths, farm track applications or minor roadways.

Paving widths range from 2 ft. 6 in. to 16 ft. 5 in. (0.75 m to 5 m) allowing the SUPER 1300-3i to handle all these tasks with effortless ease. The powerhouse is driven by a modern Deutz engine rated at 100 hp (74.4 kW).

The VÖGELE ErgoPlus 3 operating system has been supplemented by numerous ergonomic and functional features for the "Dash 3" generation. The paver operator's console, for example, comes with a large color display which provides brilliant readability even in poor lighting conditions.

The PaveDock Assistant facilitates working with this compact powerhouse.

The paver comes with an AB 340 Extending Screed for superb compaction. Heated electrically like all VÖGELE screeds, it raises standards in terms of performance and efficient electric power utilization.



01 ErgoPlus 3 operating system with numerous convenient and automatic functions.
02 Tracked paver with a large range of applications.
03 The slim design and compact overall length of this paver make it very easy to work and to maneuver on tight job sites.

04 The paver operator's platform ensures maximum visibility.
05 Large material hopper for optimum feeding with mix.
06 AB 340 Extending Screed ensures perfect paving results.

THE RIGHT PAVER FOR JOBS IN TIGHT SPACES

No component on the SUPER 1300-3i extends beyond its slim silhouette. With the hopper wings folded up, its basic width comes to no more than 6 ft. 1 in. (1.85 m) - this in conjunction with a length of just 16 ft. 3 in. (4.95 m).

As a result, the SUPER 1300-3i can be driven nearly anywhere and fits through almost any opening. Yet it can still pave up to a width of 16 ft. 5 in. (5 m)

The slim paver design without protruding edges and an overall length of no more than 16 ft. 3 in. (4.95 m) renders the machine ideal for easy paving and maneuvering in tight corners.

For passing through narrow spaces, push-rollers fold up together with the hopper wings.



Slim paver design

and compact total length of just 16 ft. 3 in. (4.95 m)

Clearance width 6 ft. 1 in. (1.85 m)

with hopper wings folded



The hardtop (option) made of glass-fiber reinforced polymer material folds down with effortless ease, thus getting the paver quickly ready for transport.



PERFECT IN MANY AREAS OF APPLICATION

With its compact dimensions and high power, the VÖGELE Compact Class of pavers delivers a wide range of different applications. Whether dealing with combined footpaths and cycle paths, farm tracks or minor roads and squares, the SUPER 1300-3i's wide range of pave widths from 16 ft. 5 in. (0.75 m to 5 m) and high engine output enable it to master any task job with ease.



- 01 Asphalt paving on combined footpaths and cycle paths**
- 02 Pavement rehabilitation on municipal roads**
- 03 Asphalt paving on railway platforms**
- 04 Pavement rehabilitation on access roads**

The applications illustrated here are typical for the VÖGELE Compact Class. Illustrations may also show the predecessor model.

FULL POWER, INTELLIGENT TECHNOLOGY

High output with low consumption

Three main components define the power unit of a SUPER 1300-3i: its modern, liquid-cooled diesel engine, a splitter gearbox flanged directly to the engine and a large cooler assembly.

The driving force in this VÖGELE powerpack is its powerful diesel engine, of type TCD 3.6L4. This four-cylinder engine delivers 100 hp (74.4 kW) at 2,000 rpm. Yet the fuel-saving ECO mode is sufficient for many applications. And even then, the SUPER 1300-3i still has a full 92 hp (68.7 kW) at its disposal. Moreover, the machine generates even less noise when running at just 1,600 rpm.

A large cooler assembly ensures that the power unit always delivers its full output. With innovative air routing and a variable-speed

fan, temperatures are continually maintained within the optimum range, significantly extending the service life of both the diesel engine and the hydraulic oil. A further advantage is that the machine can operate without difficulty in all climate regions worldwide.

All hydraulic consumers are directly supplied with hydraulic oil via the splitter gearbox. Hydraulic pumps and valves are centrally located, making them optimally accessible for servicing.

100 hp (74.4 kW)
diesel engine output

ECO mode at 1,600 rpm
reduces operating costs

Intelligent generator management
adapts output to suit pave width



VÖGELE
SUSTAINABILITY

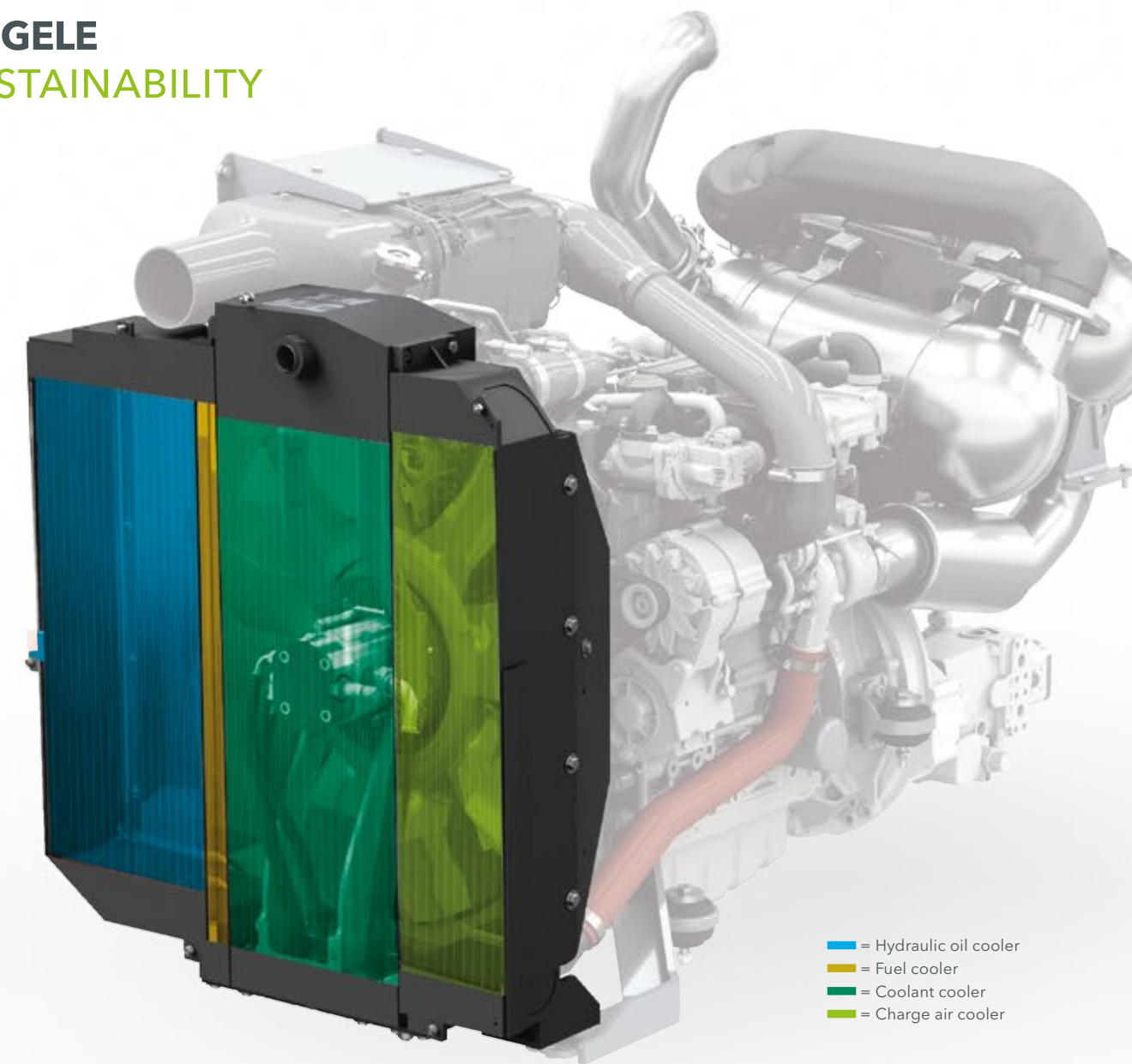

- = Hydraulic oil cooler
- = Fuel cooler
- = Coolant cooler
- = Charge air cooler

VÖGELE > GOOD TO KNOW

Exhaust emissions aftertreatment on "i" machines

On the engine of the SUPER 1300-3i, exhaust emissions aftertreatment is provided by the diesel oxidation catalyst (DOC), a diesel particulate filter (DPF) and a selective catalytic reduction (SCR) catalytic converter, so engines of the "i" machines satisfy the strict requirements of European exhaust emissions standard Stage V.

For less regulated markets, a variant without exhaust emissions aftertreatment is available. This corresponds to European exhaust emissions standard stage 3a and US standard EPA Tier 3.

EFFICIENT TRANSLATION OF TRACTIVE POWER

Thanks to their high-quality separate, hydraulic drives, our pavers operate exceedingly cost-efficiently, achieving a high level of performance. With its powerful crawler tracks, the SUPER 1300-3i easily pushes heavy feed vehicles and achieves great tractive effort also on soft bases even when paving in large widths. In terms of traction, the VÖGELE drive concept for tracked pavers leaves nothing to be desired.

The hydraulic systems for the traction drive, conveyors and augers as well as the compacting systems all operate in separate closed circuits for maximum efficiency.

> Long crawler tracks with large footprints provide for maximum tractive effort, allowing the paver to get on well at a constant speed even when operating on difficult terrain.

> Positive tracking when moving straight and accurate cornering due to separate drive and electronic control provided for each crawler track.

> Thanks to powerful separate drives fitted into the drive wheels for the crawler tracks, engine output is translated into paving speed with maximum efficiency.

Powerful separate drives
fitted into the sprockets

Positive tracking when moving straight ahead
with electronic control of each crawler track



PERFECT MATERIAL MANAGEMENT FOR PERFECT PAVING QUALITY

A continuous flow of material is key to ensuring uninterrupted and high-quality paving. That is why we attach such importance to professional material management when designing our pavers. All our development efforts focus on simple operation and the best possible overview for the paving team.

When feeding the paver with material becomes difficult on narrow job sites, then the large capacity of the SUPER 1300-3i's material hopper still ensures that an optimal amount of mix is supplied in front of the screed. Thanks to a hydraulically operated hopper apron (option), no spills of material when feed trucks change. Directs the mix inside the material hopper right onto the conveyors for complete emptying. No hand work with shovels required.

The large material hopper holding 22,000 lbs. (10 tonnes) is dimensioned so that a sufficient quantity of mix is stored at all times, especially when shuttling in and out of areas where direct feeding of the paver is not possible.

Individually and hydraulically operated hopper wings provide a consistent material flow, even when paving in asymmetrical width along boundaries such as walls.



Large material hopper
with a capacity of 22,000 lbs. (10 tonnes)

Deep and wide hopper sides
for especially straight forward material feed

Oscillating push-rollers
for convenient docking without jolting



01

- 01** Thanks to an amply dimensioned conveyor tunnel and powerful separate hydraulic drives provided for conveyors and augers, the SUPER 1300-3i achieves laydown rates up to 390 tons/h (350 tonnes/h), a performance extraordinarily high for a paver in its class.
- 02** Separate drive and control is installed for each conveyor and each auger. When operating in automatic mode, conveyors and augers are subject to continual monitoring. Proportional control provides for a constant head of material in front of the screed.
- 03** Automatically folding limiting plates for the auger tunnel are provided to quickly set up the machine for paving within the range of 8 ft. 6 in. and 13 ft. 9 in. (2.6 m to 4.2 m). There is no need for conversion.



02



03

The conveyance and spreading of mix in front of the screed is optimal thanks to the large conveyor tunnel, proportional control of conveyors and powerful augers. Furthermore, augers adjustable

in height and folding limiting plates for the auger tunnel allow the paver to be moved on the job site without a need for conversion. This saves time and money.

VÖGELE > GOOD TO KNOW

Adjustable auger height

The height of the auger - complete with bearing boxes and limiting plates for the auger tunnel - can be manually adjusted by up to 5 inches (13 cm) across full pave width. This optimizes the head of mix in front of the screed, even when paving thin layers or when layer thickness within a paving section varies.

The AutoSet Basic option allows the auger to be moved to transport position hydraulically at the touch of a button and, following repositioning, to be returned to the previously set height in exactly the same way.



AUTOSET BASIC REPOSITIONING FUNCTION

AutoSet Basic is especially helpful when the machine has to be moved on the job site frequently.

Simply pressing the "Execute" button hydraulically raises the augers, the hopper front and the deflectors in front of the crawler tracks to their uppermost positions. The screed, too, is brought into its transport position. The conveyors are temporarily reversed, preventing mix from falling to the ground when the paver travels to the next work section on site.

Once the paver has been repositioned, pressing the "Execute" button again returns all systems to the previously-stored working position.

This ensures that no settings are lost when switching from paving to repositioning or transport. It also effectively prevents any damage to the machine.



AutoSet Basic repositioning function

The AutoSet Basic repositioning function is activated just by pushing the "Execute" button.

- 01 Raise/lower screed.
- 02 Raise/lower auger.
- 03 Conveyor movement reversible for a short time.
- 04 Raise/lower deflectors in front of the crawler tracks.
- 05 Raise hopper front.

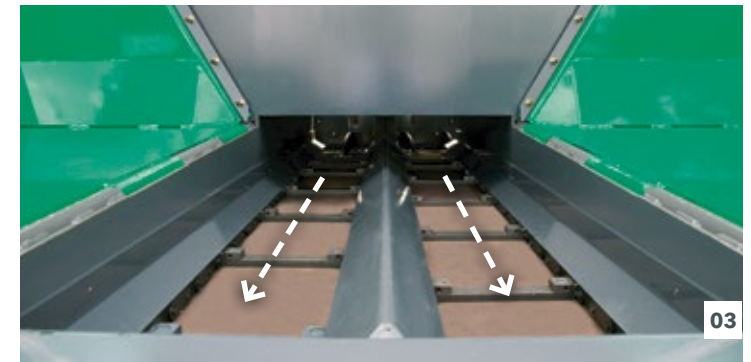



ERGOPLUS 3 OPERATING CONCEPT

Improved efficiency, reliability and convenience

Even the very best machine with the most advanced technology can only really show its strengths if it can be operated easily and as intuitively as possible. At the same time, it should offer an ergonomic and safe working environment for the operating team.

Therefore, the ErgoPlus 3 operating system focuses on the operator. With VÖGELE pavers, the operator consequently retains full control over the machine and construction project. On the following pages, example illustrations will provide you with more detailed information on the extensive functions of

the ErgoPlus 3 operating system. ErgoPlus 3 encompasses the operator's stand, the paver operator's console, the screed consoles and Niveltronic Plus, the System for Automatic Grade and Slope Control.



THE ERGOPLUS 3 PAVER OPERATOR'S CONSOLE

Clearly arranged in line with experience from the field

The paver operator's ErgoPlus 3 console has been designed according to practice-related principles. All controls are clearly arranged. Paver functions are clustered in logical groups so that operators find their controls just where they would expect them to be.

On the ErgoPlus 3 console, all push-buttons are easily identifiable by touch even when wearing work gloves. Once a button is pressed, off you go thanks to the "Touch and Work" principle. This means that a function is executed directly - without the need to confirm.



01 Conveyors and augers, traction

All controls for the conveyor and auger are located here. The traction main switch, the operating mode selector and the setpoint adjuster for the pave speed are also included in this function group.

02 Material hopper and steering

This function group includes the controls for the material hopper, the steering and the diesel engine. Various options are also operated from here.

03 Screed functions

All controls for the screed are grouped in the center of the paver operator's console.

04 Display of the paver operator's console

The redesigned color display has a high-contrast user interface ensuring brilliant readability even in poor lighting conditions. Vital information is shown on menu level 1, such as the positions of the screed tow point cylinders or the material level in the conveyor tunnel. Further paver functions such as speeds for tamper and vibration or feed rates for the conveyors can easily be set up via the display, too. And the display gives access to machine-related information such as fuel consumption or service hours.

05 Safe operation during the night

Glarefree backlighting comes on automatically as darkness sets in so that the paver operator can also work safely on night-time jobs.



CONVEYORS AND AUGERS, TRACTION

Module 1

01 Choice of operating modes for the paver

On the ErgoPlus 3 console, 4 different operating modes for the paver are available to select from. By pressing the arrow buttons, up or down, the operator changes modes in the following order: "Neutral", "Job Site", "Positioning" and "Paving". An LED indicates the mode selected.

02 Automatic functions for material handling/distribution

These functions ensure that adequate mix for paving is automatically conveyed and distributed in front of the screed. The level of the head of mix in front of the screed is defined by a material sensor and the automatic system ensures that this remains constant. The function is only active during paving - if the paver stops, so does material handling.

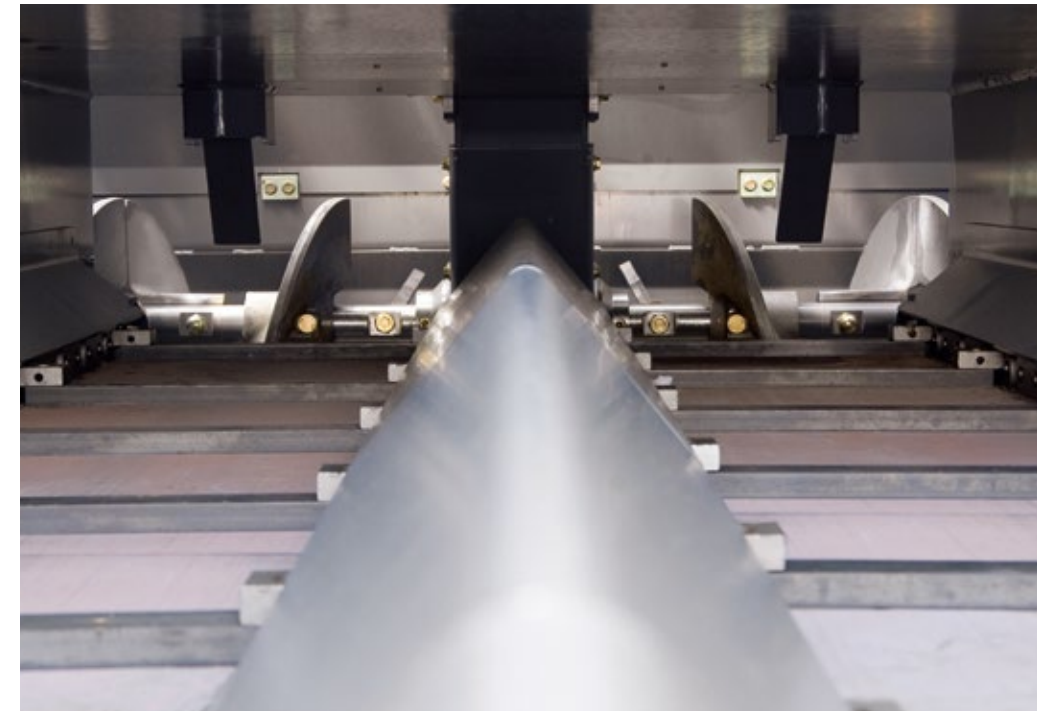

The conveyor can be reversed at the touch of a button. Return transport of the mix is automatically stopped. The conveyor can be switched to the no-load function just as quickly.



- 01 Choice of paver operating modes
- 02 Automatic functions for material handling/distribution
- 03 Conveyor reversing
- 04 Idling function

03 Conveyor reversing

In order to stop mix dropping off the conveyors when moving the paver on the job site, conveyor movement can be reversed at the touch of a button. Reverse movement takes place for a short time only and stops automatically.

04 Idling function

Idling function is provided for the warm-up or cleaning of conveyors, augers and tamper.

MATERIAL HOPPER AND STEERING

Module 2

01 Choice of engine speed ranges

For the engine, there is a choice of three modes: MIN, ECO and MAX. To switch modes for engine speed, all the operator needs to do is press the up or down arrow buttons. In ECO mode, the engine delivers sufficient power for a great number of paving applications. Running in ECO mode significantly reduces noise and fuel consumption.

02 PaveDock Assistant (option)

The paver operator can use the PaveDock Assistant signal lights to give the driver of the feed vehicle clear signals indicating what needs to be done (e.g. reverse, stop, dump mix). The lights are conveniently activated directly from the paver operator's ErgoPlus 3 console.



01 Choice of engine speed ranges
02 PaveDock Assistant (option)

03 Steering

For a large turning circle, fine steering allows pre-setting of a track position which is maintained automatically with no need for manual intervention by the operator.



- 01 Choice of engine speed ranges
- 02 PaveDock Assistant (option)
- 03 Steering at a pre-selected steering angle

SCREED

Module 3

All the key screed settings can be made from the paver operator's console. The screed can be raised or lowered here, each of the two sides of the screed extended or retracted, or the angle of the screed adapted to suit conditions. This means the paver operator, too, has access to the screed at all times.

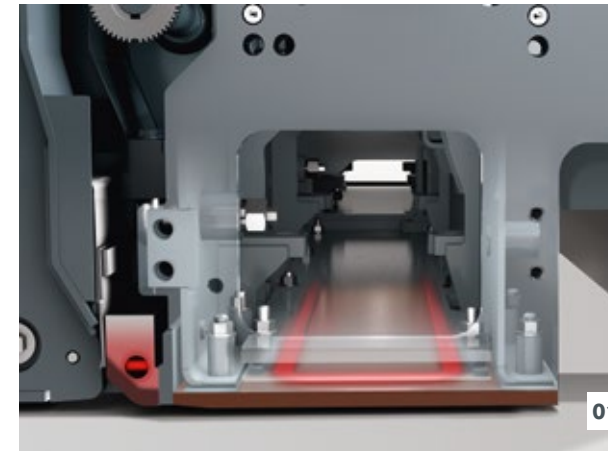

01 Screed heating

In order to optimize compaction and produce a smooth surface texture, all compacting elements are heated across full screed width. Screed heating is switched on or off at just the touch of a button. To ensure the screed heating system is working properly, an automatic function check is carried out when it is switched on.

02 Screed Assist (option)

This button switches Screed Assist on (LED lights up) or off. Screed Assist pressure and balance can be set on the display. Screed Assist is active only when the screed is floating.

01 Screed plates are fitted as standard with heating elements which distribute the heat throughout the plates.

02 When the screed is in the floating position, the Screed Assist feature can also be activated.

01 Screed Heating

02 Screed Assist (option)

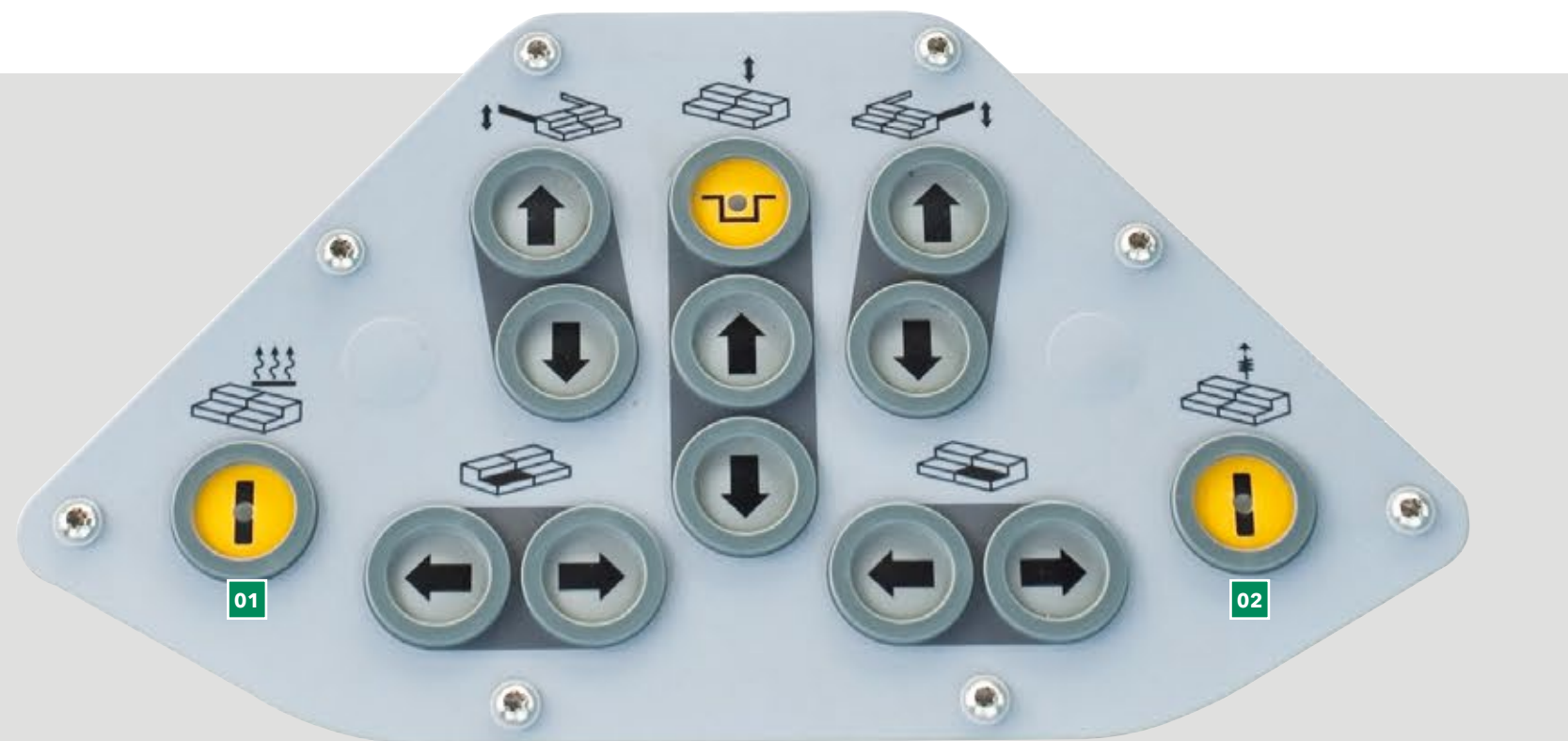

THE ERGOPLUS 3 SCREED CONSOLE

The screed is crucial for pavement quality. Therefore, easy and positive handling of all screed functions is of utmost importance for high-quality road construction.

With ErgoPlus 3, the screed operator has the process of paving at his fingertips. All functions are easily comprehensible and all controls are clearly arranged.

The screed console is designed in keeping with the conditions prevailing on the job site. Push-buttons are provided for the frequently used functions operated from the screed console. These are watertight and enclosed in palpably raised rings, so that they are identifiable blindfolded simply by touch even when wearing work gloves. Important paver and screed data can be called up and adjusted from the screed console, too.



01 The screed console is specially designed for night-time operation. To prevent operator errors, the buttons are backlit as soon as dusk falls or in darkness. What is more, the downward-angled high-power LED lighting gives the operator a perfect view of all processes associated with the end gate.

02 The screed width can be effortlessly adjusted by means of the "SmartWheel".

01 The display of the screed console

The screed console display allows the screed operator to control and monitor both the left and the right side of the screed. Machine-related parameters such as vibration speed or conveyor speed can be adjusted conveniently via the display panel of the screed console. The clear menu structure, combined with easily understandable, self-explanatory symbols neutral in language, makes operating the display panel both simple and safe.

02 Ergonomic screed width control in two speeds

The screed width can be effortlessly adjusted by means of the "SmartWheel". This is done in two speeds: slow, for precise control e.g. along an edge, or fast, for rapid extension or retraction of the screed.

03 Crown adjustment at the press of a button

The crown can be conveniently adjusted at the press of a button on the screed operator's console. When pressing the "plus" or "minus" keys, the set crown value is shown on a pop-up window. The conveyors and augers are adjusted accordingly.

01 The display of the screed console

02 Ergonomic screed width control in two speeds

03 Crown adjustment at the press of a button

NIVELTRONIC PLUS

System for Automatic Grade and Slope Control

Niveltronic Plus, the System for Automatic Grade and Slope Control, is an in-house development by VÖGELE based on many years of experience in grade and slope control technology. Easy operation, precision and reliability are its hallmarks, ensuring perfect mastery of all grade and slope control jobs.

This fully integrated system is optimally adapted to the machine technology of the Premium Line pavers. All wiring and connections, for instance, are integrated into the tractor, effectively eliminating all risk of damage to these components.

VÖGELE naturally offer a particularly large and practical selection of sensors permitting versatile use of the Niveltronic Plus system. Whether for instance car parks, roundabouts or highways need to be built or rehabilitated, VÖGELE offer the right sensor for every job site situation.

Sensors can be changed quickly and easily, for Niveltronic Plus automatically detects which sensor is connected, thus simplifying the configuration process for the user.



01



02



03

- 01 The LED sighting crosses also fitted to the sensor provide continuous, clearly visible feedback to the screed operator indicating whether the actual values match the settings made.
- 02 A variety of sensor types are available for Niveltronic Plus, in keeping with the machine's extensive and varied range of applications. These sensors extend from a mechanical sensor to non-contacting sonic sensors.
- 03 The two-way split display provides the screed operator with access to both sides of the screed. The symbols provide information at all times including on the height of the tow point rams, the preset and actual values, and the preset sensitivity of the grade and slope control sensors.



01

02

03

VÖGELE > GOOD TO KNOW



Available sensors

Slope sensor

The slope sensor allows the transverse profile to be determined exactly and then paved accurately. The measuring range is +/- 10%.

Variable mechanical grade sensor

The variable mechanical grade sensor can be equipped with skis for referencing from the ground in 30 cm, 1 m and 2 m lengths.

Single-cell sonic sensor

The single-cell sonic sensor emits a sound cone, allowing it to copy references 1:1 without calculating an average. It can be used for referencing from the ground (Ground mode) or from a tensioned wire (Stringline mode).

Multi-cell sonic sensor

The multi-cell sonic sensor, with its four sensors, is highly versatile. By calculating an average, it can compensate for short irregularities in a reference.

Big MultiPlex Ski

The Big MultiPlex Ski compensates for extended undulations. Its 5 to 13 meter (16.4 to 42.6 ft) beam can be fitted with three multi-cell sonic sensors as standard - or with up to five if required.



01



02



03



04



05



06

OPERATOR'S ERGOPLUS 3 PLATFORM

Improved efficiency, reliability and convenience

An ergonomic workstation is of key importance to enable a paver operator to concentrate fully for long periods of time, which is why VÖGELE relies on the paver operator's stand with ErgoPlus 3. The operator's ErgoPlus 3 stand provides plenty of storage space, is clearly arranged and meets stringent health and safety requirements.

Outstanding all-round visibility also increases safety. The operator can monitor everything from his workstation: material feed, material supply and head of mix. With its intelligent design, the ErgoPlus 3 system proves that innovative technology can be controlled ergonomically, efficiently, intuitively and conveniently.

01 The comfortable operator's stand

> The comfortable operator's stand gives an unobstructed view of all important areas of the paver such as material hopper, steering guide, and screed. It allows the paver operator to easily monitor the paver's material feed.

02 Control console and seats can be moved for an optimum seated position

> The seats swinging out to the sides and an operator's stand of streamlined design provide for maximum visibility of the auger tunnel, permitting the paver operator to keep an eye on the head of mix in front of the screed at all times.

> The operator's stand with its streamlined design is well organized, offering the paver operator a professional workplace. The operator console is protected by a cover to prevent unauthorized access and vandalism.

03 Hardtop gives excellent protection

> A modern hardtop made of glass-fiber reinforced polymer material shelters the operator whether rain or shine.

04 Consistent service concept

> All "Dash 3" pavers have a consistent maintenance concept with identical service intervals.

05 Safe and comfortable ascent

> The walkway and comfortable middle ascent on the screed ensure safe and convenient access to the operator platform.

06 Ergonomic screed console

> The height and position of the console are easily adjusted. The high-contrast color display can be read clearly from all angles.

For SUPER 1300-3i, the AB 340 Extending Screed is the perfect match. The screed with a basic width of 5 ft. 11 in. (1.8 m) extends hydraulically up to 11 ft. 2 in. (3.4 m). By addition of bolt-on extensions, it builds up to a maximum width of 16 ft. 5 in. (5 m). The unique VÖGELE single-tube telescoping system allows screed width control, accurate to the millimeter, up to 11 ft. 2 in. (3.4 m).

A typical VÖGELE feature also found in the AB 340 Extending Screed is electric heating. The modern, powerful screed heating system provides for quick and uniform heating to operating temperature, an essential for smooth surface texture. Excellent insulation of the screed plates reduces loss of heat to a minimum. Heating the screed takes a short time only, even with the engine running at minimum rpm.

In automatic operation, the screed is heated in alternating mode, which means that only one half is heated at any one time, thus sparing the engine and saving fuel.



Innovative screed heating

In order to optimize compaction performance and to produce a smooth surface structure, all compacting elements are heated across full screed width. Screed plates are fitted as standard with heating elements which distribute heat throughout the plates. The plates are thoroughly insulated on top so that 100% of the heat is directed to where it is needed: the area of contact with the mix. The tamper bar is fitted with heating rods for quick and uniform heating from the inside. Sophisticated control technology is installed to allow automated management of screed heating.

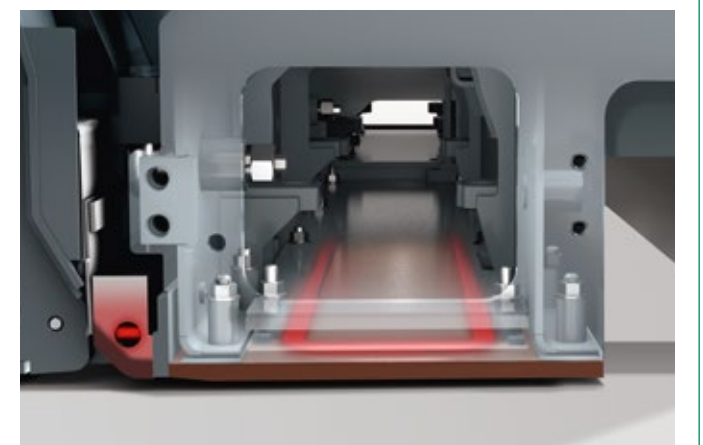



AB 340

Paving widths

- > Infinitely variable range from 5 ft. 11 in. (1.8 m) to 11 ft. 2 in. (3.4 m)
- > Maximum paving width achieved with bolt-on extensions:
 - > AB 340 V: 13 ft. 9 in. (4.2 m)
 - > AB 340 TV: 16 ft. 5 in. (5 m)
- > Smaller widths by fitting cut-off shoes down to a minimum of 29 in. (75 cm)

Compacting systems

- > AB 340 V with vibration
- > AB 340 TV with tamper and vibration

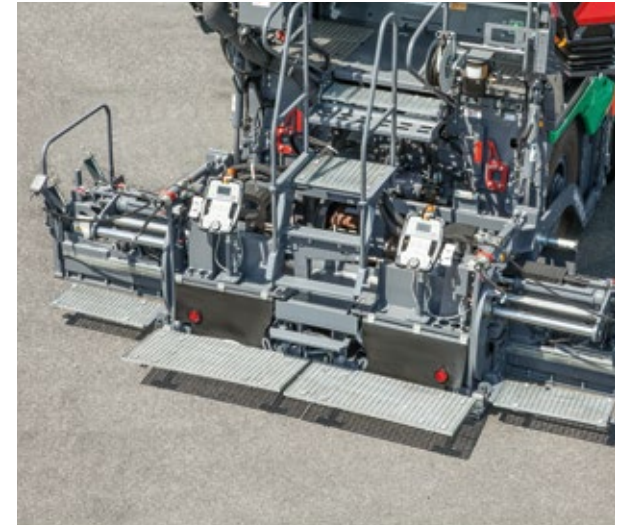

AB 340 V/TV with 10 in. (25 cm) bolt-on extensions

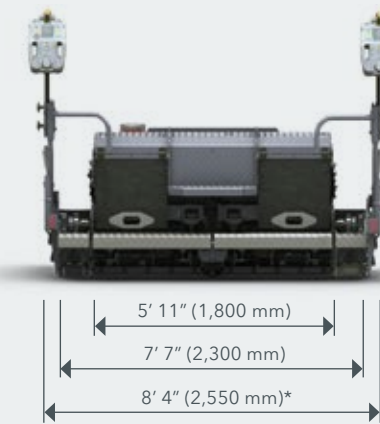

Easy Transport
*Even with bolt-on extensions and end gates fitted, the transport dimensions do not exceed 8 ft. 4 in. (2.55 m).

AB 340 TV built up with 31 in. (80 cm) bolt-on extensions

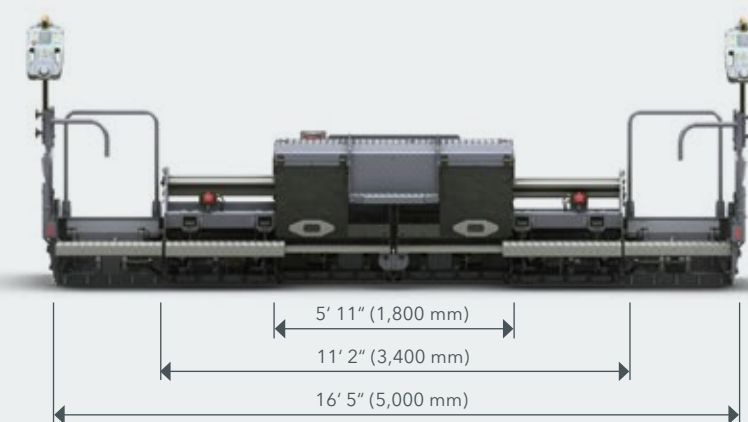

WIRTGEN GROUP CUSTOMER SUPPORT

Service you can rely on.

You can have confidence in reliable, swift support from us during the entire life cycle of your machine. Our wide range of services offer the right solution to any challenge you face.



Service

We keep our service promise with swift, straightforward assistance - on the job site or at our professional workshops. Our service team is trained to a professional standard, and dedicated tools ensure that repair, care and maintenance tasks are completed quickly. We can support you with customized service agreements on request.

> www.wirtgen-group.com/service



Spare parts

WIRTGEN GROUP original parts and accessories assure the long-term reliability and availability of your machines. Our experts will also be pleased to advise you about optimized wear part solutions to match your application. Our parts are available all over the world at all times, and are easy to order.

> parts.wirtgen-group.com



Training

The WIRTGEN GROUP brands are specialists in their field, with decades of experience in applications. Our customers benefit from that expertise.

Through our WIRTGEN GROUP training courses, we are delighted to pass our knowledge on to you, customized to suit both operators and servicing staff.

> www.wirtgen-group.com/training



Telematics solutions

In the WIRTGEN GROUP, construction machinery featuring leading-edge technology goes hand in hand with advanced telematics solutions. Intelligent monitoring systems such as WITOS or JD Link* not only make it easier for you to plan the maintenance of your machines, they also improve productivity and efficiency.

> www.wirtgen-group.com/telematics

* WITOS and JD Link are currently not available in all countries. Please contact your local subsidiary or dealer for more information on this.

ALL THE FACTS AT A GLANCE

SUPER 1300-3i Tracked Paver



TECHNICAL DATA

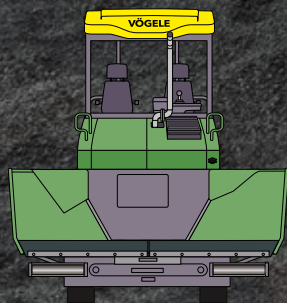
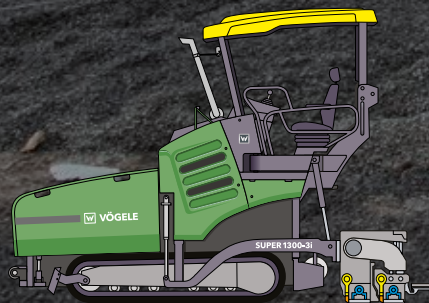

SUPER 1300-3i

- > Maximum paving width: 16 ft. 5 in. (5 m)
- > Maximum laydown rate: 390 tons/h (350 tonnes/h)
- > Layer thickness: up to 10 in. (25 cm)
- > Transport width: 6 ft. 1 in. (1.85 m)



Wirtgen America, Inc.

6030 Dana Way
Antioch, TN 37013
USA

T: 615 501-0600
F: 615 501-0691

 www.wirtgen-group.com/america



For more information, scan the QR code.