

Compact and heavy-duty high-performance cold milling machine

COLD MILLING MACHINE W 220 Fi



COMPACT AND HEAVY-DUTY HIGH-PERFORMANCE COLD MILLING MACHINE

The heavy-duty cold milling machine handle a wide range of applications, from surface layer rehabilitation to complete pavement removal and fine milling.

Rapid milling drum assembly changes and particularly fast milling drum changes for milling widths of 2,2 m, 2,5 m, 3,5 m or 3,8 m thanks to the MCS (Multiple Cutting System) further expand the machine's wide range of applications.

In automatic mode, the innovative **MILL ASSIST** machine control system always selects the best ratio between performance and costs - in addition, an operating mode can be selected based on cost, performance, or quality.

Thanks to the unique **DUAL SHIFT** powershift transmission with extended milling drum speed, the W 220 Fi is the perfect choice for particularly demanding milling tasks.

A host of innovative features significantly reduce fuel consumption and pick wear, thereby boosting sustainability and minimizing CO₂ emissions.

WIRTGEN COLD MILLING MACHINES



SMALL MILLING MACHINES

- > Milling width up to 1,300 mm
- > Milling depth to 300 mm

COMPACT MILLING MACHINES

- > Milling width up to 1,900 mm
- > Milling depth to 330 mm

LARGE MILLING MACHINES

- > Milling width up to 4,400 mm
- > Milling depth to 350 mm

OVERVIEW OF HIGHLIGHTS

Perfectly Equipped

OPERATION

- 01 Exceptional Comfort on the Operator's Platform**
 - > Perfect view of important working areas
 - > High-performance LED lighting
 - > Generously sized storage space
 - > Powerful heater for operator's platform
 - > Variable, vertically adjustable weather canopy
 - > SMART KEY to save user-specific machine parameters

- 02 Intuitive MMI - Man Machine Interface**
 - > Flexible control panel concept for maximum machine control
 - > 2" control panel with favorites buttons
 - > 5" control panels for leveling
 - > 7" control panels conveniently display important information
 - > Heavy-duty, high-quality camera / monitor system with 10" control panel

QUALITY

- 03 High-Precision, Versatile LEVEL PRO ACTIVE Leveling System**
 - > New, easy-to-use **LEVEL PRO ACTIVE** operating concept
 - > Numerous additional and automatic functions
 - > Optimized 3D and laser leveling
 - > Leveling boom with Sonic-Ski sensor on both sides
 - > Optimized multiplex system

- 04 High Reliability**
 - > Groundbreaking diagnostic concept
 - > Redundant machine control
 - > Robust, reliable CAN network
 - > Reliable vandalism protection
 - > Time-saving service and maintenance concept



MILLING

05 One-Of-A-Kind Cutting Technology

- > Rapid milling drum changes thanks to **MCS BASIC**
- > Simple milling drum assembly changes
- > Optimized protection against milling drum assembly wear
- > Extremely wear-resistant **HT22** quick-change toolholder system
- > New **HT22 PLUS** toolholder upper part with increased service life

06 Innovative MILL ASSIST 

- > **MILL ASSIST** automatic mode for maximum cost efficiency
- > Additional pre-selection of an operating strategy in automatic mode
- > Clear pre-selection of constant milling pattern quality
- > Innovative efficiency indicator
- > New **DUAL SHIFT** powershift transmission

PERFORMANCE

07 Maximum Milling Performance

- > Powerful diesel engine
- > Increased ballasting flexibility
- > Large scraper lift with high setting depth
- > Flexible and powerful loading of milled material
- > **ACTIVE CONVEYOR** for swinging the discharge conveyor relative to the steering angle

08 Informative WPT - WIRTGEN PERFORMANCE TRACKER

- > Field-tested WITOS FleetView telematics system
- > Optional additional equipment **WPT** for clear documentation of milling performance
- > Automatically generated measurement reports
- > Job site tracking via satellite map display
- > Documentation of consumables to calculate operating costs



ECONOMY AND SUSTAINABILITY

09 Reduced Diesel Consumption - Active Minimization of CO₂ 

- > 2-speed powershift transmission for a wide range of usable milling drum speeds
- > Automatic stop feature for the diesel engine
- > Maximum performance in the low speed range
- > Automatic start-stop feature of the milling drum
- > Dual fan concept for optimum cooling

10 Environmentally Friendly Machine Technology 

- > Maximum exhaust gas purification for low exhaust emissions
- > Reduced noise emissions during relocation
- > Optimized VCS extraction system
- > ECO operating strategy for minimal consumption
- > Start-stop engine function via external control panel
- > Efficient water management



WIRTGEN SUSTAINABILITY describes innovative technologies and solutions which are consistent with the sustainability objectives of the WIRTGEN GROUP.

CONNECTED MILLING

An efficient flow of information is the key to making processes easier, faster, and more cost-effective. WIRTGEN has been committed to this approach for many years and refers to the topic in the field of milling technology as **CONNECTED MILLING**.

CONNECTED MILLING refers to the innovative, diverse flow of information between the machine and its various components, the machine operator, the service workshop, and the scheduling offices. This available data and information can be used to make milling operations even more efficient and further increase machine reliability.

In the new generation of large milling machines, the latest, innovative **CONNECTED MILLING** features include the **MILL ASSIST** intelligent assistance system and the **WIRTGEN PERFORMANCE TRACKER** high-precision milling performance measurement system.

MILL ASSIST can be used to assess relevant information such as engine load, milling drum type, milling depth, or traveling pressure, for example, in order to set the optimum milling drum speed. In addition, the machine operator can pre-select a work strategy with respect to costs, performance, or quality.

The **WIRTGEN PERFORMANCE TRACKER** uses a laser scanner to measure the cross-sectional profile to be milled. Surface milling performance and milling volume are then precisely measured using GPS positioning and other sensors. Afterwards, an automatically generated report is created that documents the daily milling performance, including all consumables, a precise site plan, and a wealth of other information, which is then sent to the machine dispatcher, for example. The machine operator receives important information directly via the control panel display.

In WIRTGEN's new generation of large milling machines, **CONNECTED MILLING** becomes even more important for machine operators.



**MACHINE
OWNER**

**COLD MILLING
MACHINE**



**CONNECTED
MILLING**



OPERATOR

EXCEPTIONAL COMFORT ON THE OPERATOR'S PLATFORM

Perfect View of Important Working Areas

The large milling machine's intelligently designed visibility concept makes the operator's work much easier and results in precise milling results. For example, the operator's platform can be extended to the right by more than 20 cm beyond the edge of the machine to guarantee that the operator has an unobstructed view of the area to be milled and the loading of the milled material. In addition, the narrow chassis is designed with a wasp waist at the front left and right as well as at the back right. This means that the operator always has a good view of the crawler unit and milling edge.

High-Performance LED Lighting

The W 220 Fi has particularly powerful LED working lights all around the machine, lighting for the operator's platform, and "welcome and go home" lighting for comfortable access. In addition, the machine also features control panel lighting, lighting for the milling drum assembly including auxiliary working lights for tool changes, and optional LED lighting balloons. This guarantees optimum machine illumination, even in difficult lighting conditions.



Excellent Visibility

Clear view of operations

Warm on the Job

Powerful platform heating

- 01** Ergonomically designed operator's platform.
- 02** Optimum heating for the operator's hands and feet.
- 03** Individually, vertically height-adjustable weather canopy.
- 04** Weather canopy in transport position.

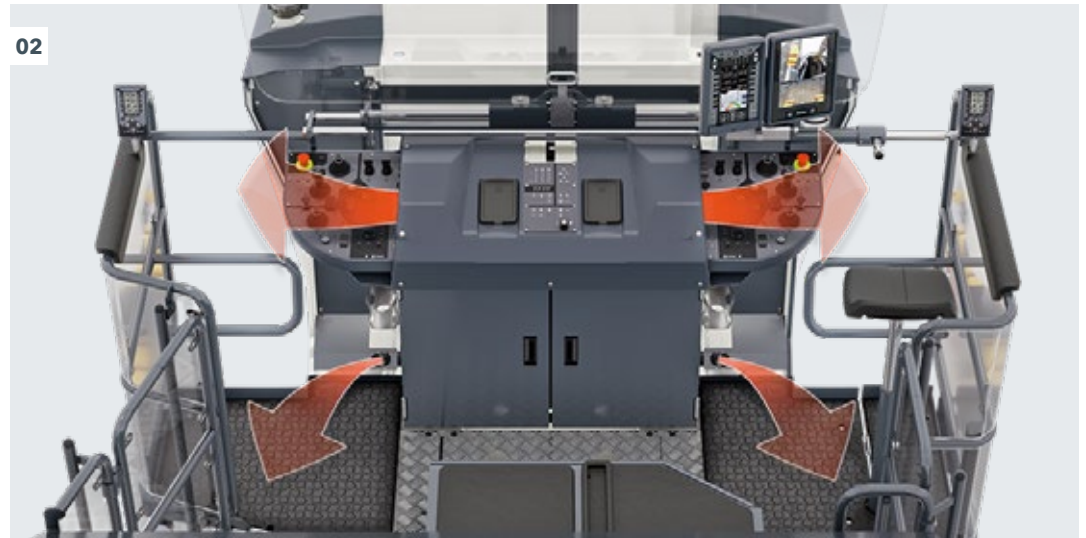

Generously Sized Storage Space

The W 220 Fi offers plenty of storage space for leveling sensors, pick ejectors, and tool buckets. The 1,620-liter, additional and optional XXL storage compartment at the rear of the machine can hold up to 72 pick buckets, while another 265-liter storage compartment on the operator's platform can also be used as an option.

Powerful Heater for Operator's Platform

The cold milling machine is equipped with a high-performance heater for the operator's platform. Intelligently arranged air vents positioned near the operator's hands and feet guarantee an excellent heating effect. In addition, the generated heat is effectively kept close to the operator by lateral wind and weather protection elements and the lowerable weather canopy.

Variable, Vertically Adjustable Weather Canopy

The height of the hydraulically height-adjustable weather canopy can be individually adjusted based on the respective operating and weather conditions. The height of the canopy can be adjusted at the touch of a button during milling operation, e.g. to avoid low-hanging branches on a street lined with trees. In addition, the heavy-duty windshields are equipped with window wipers. Exterior canopy panels that can be moved independently of each other provide additional protection in the event of rain. The operator's platform railings are also equipped with wind and weather protection elements.

SMART KEY

The SMART KEY key fob can be used to save individually adjustable machine parameters such as the display configuration or the assignment of favorites buttons. The user-specific data can be saved on five different key rings and easily transferred to other cold milling machines.

INTUITIVE MMI - MAN MACHINE INTERFACE

Flexible Control Panel Concept for Maximum Machine Control

The new control panel concept makes it possible to combine different control panels to meet specific customer requirements. The comprehensive and clear status, diagnostics, and informational display for the machine operator was an essential requirement for the WIRTGEN development engineers. The new, easy-to-understand, intuitive control panel concept optimally meets these requirements.

2" Control Panel with Favorites Buttons

In addition, up to two 2" control panels can be added to the operator's platform. In this context, the position of the panel on the left and right external railings of the operator's platform makes operation easier and more effective. It can be programmed with up to 21 individually selected functions, such as swinging the discharge conveyor.

5" Control Panels for Leveling

For leveling with the **LEVEL PRO ACTIVE** leveling system, up to two additional 5" control panels on the right and left of the machine can be optionally fitted for ground crews

7" Control Panels Conveniently Display Important Information

Whether up top on the operator's platform or at the lower operating positions, the new control panel concept provides comprehensive and clear information. As such, the 7" control panel offers all of the machine operators the following displays, for example: Machine load conditions, temperatures, hydraulic pressures, diesel and water levels, leveling control, status and diagnostic messages, and general information such as the current time.

01



Maximum Control

Individual control panel concept

Always Fully Informed

Comprehensive overview at all operating positions

01 Individual, user-friendly panel layout.

02 Overview of the different control panels and their positions.

02

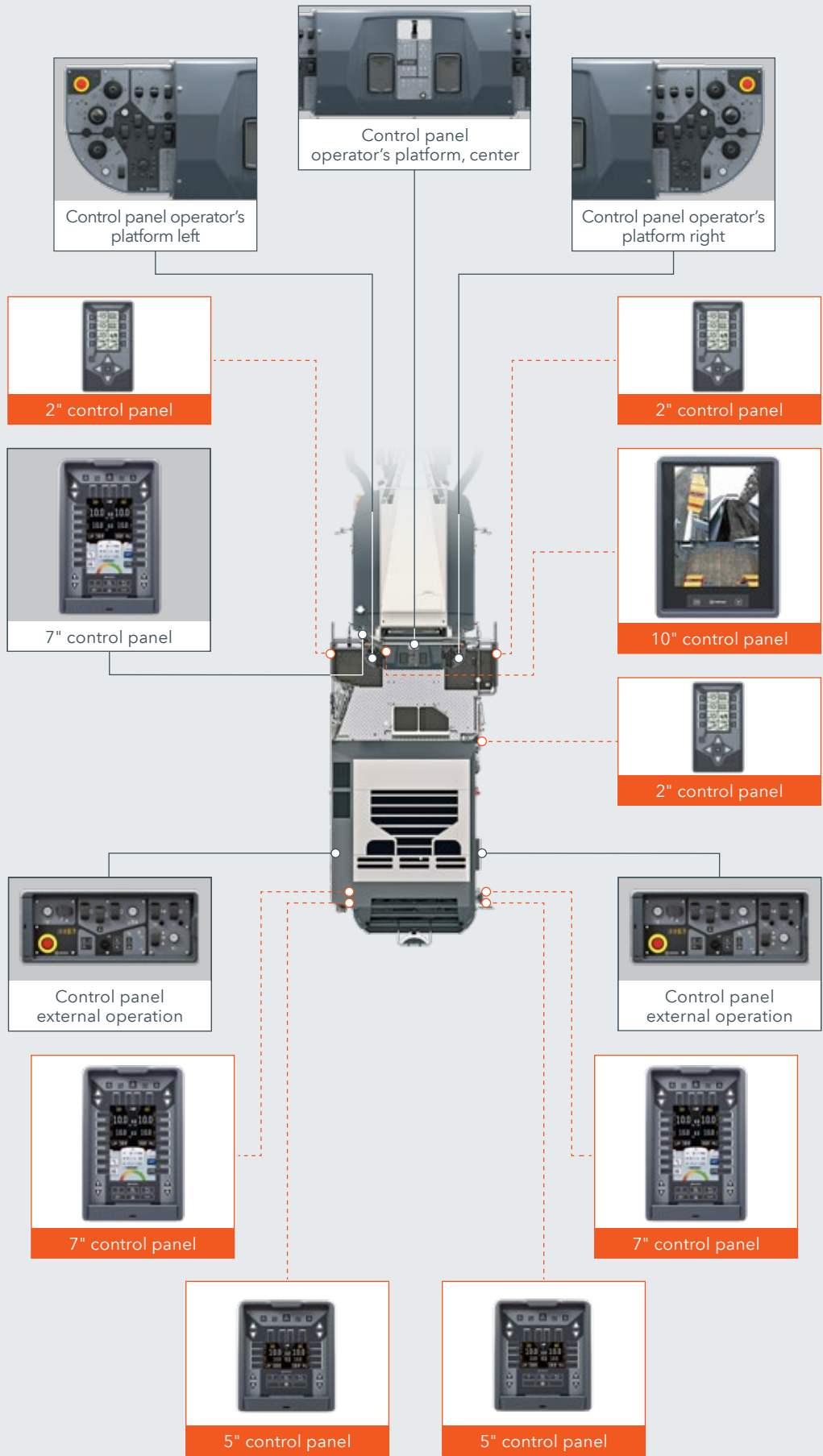

□ = Standard control panels
 □ = Optional control panels



INTUITIVE MMI - MAN MACHINE INTERFACE

Heavy-Duty, High-Quality Camera / Monitor System with 10" Control Panel

A two-camera, four-camera, or eight-camera system is also optionally available. In the two-camera system, the camera images are displayed on the 7" control panel on the operator's platform. The four-camera and eight-camera systems

also come with a 10" control panel that can display several camera images simultaneously via split screen. The heavy-duty camera / monitor systems provide the operator a clear view of important working areas, such as where the material is loaded onto trucks or the milled surface behind the scraper.

01



01 10" control panel with split screen to simultaneously display several camera images.

02 Optional 5" control panel to display leveling information to ground crews.

03 Various camera systems to provide a clear view of important areas.

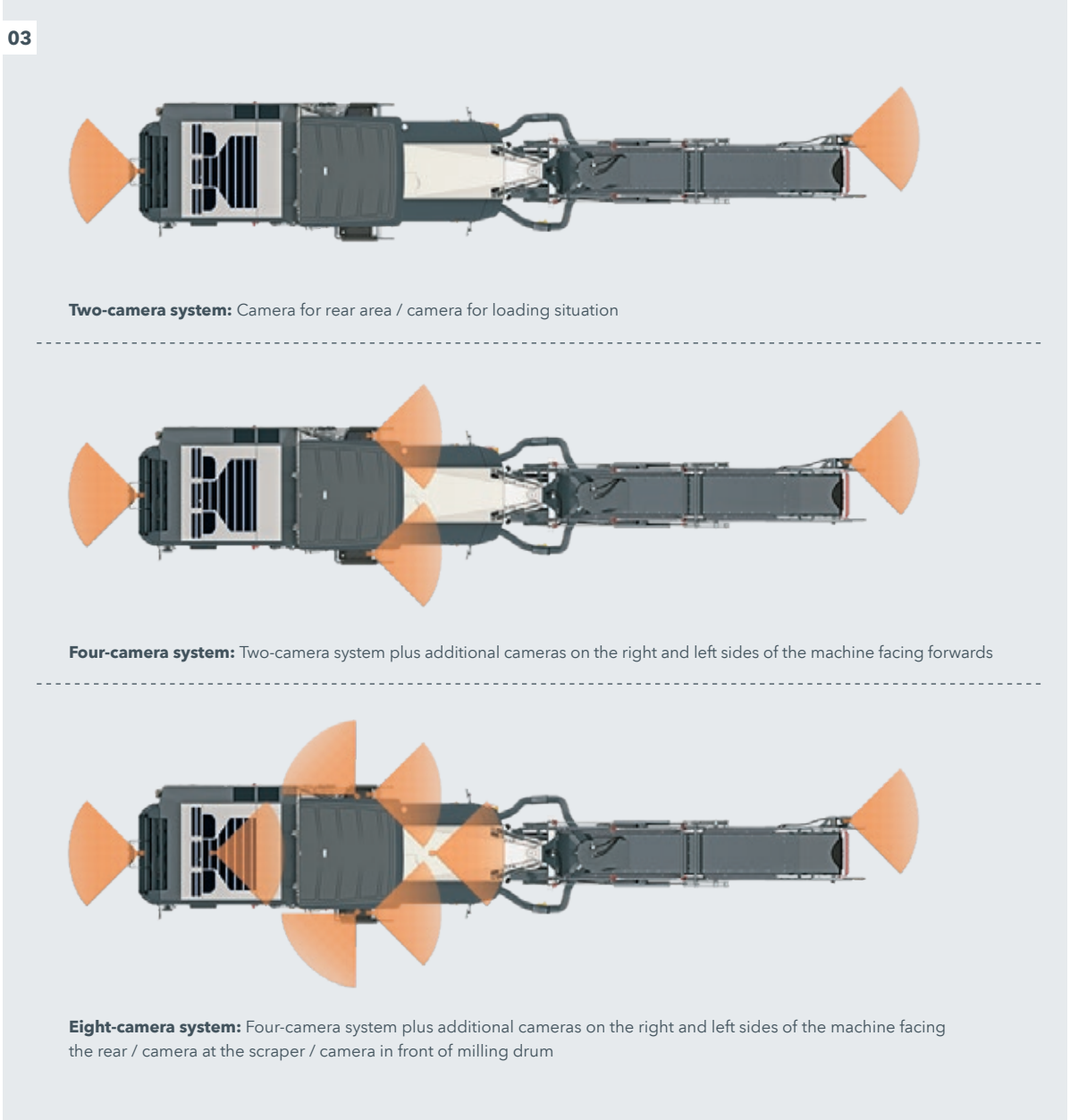

HIGH-PRECISION, VERSATILE LEVEL PRO ACTIVE LEVELING SYSTEM

New, Easy-To-Use LEVEL PRO ACTIVE Operation Concept

The new **LEVEL PRO ACTIVE** leveling system especially developed for cold milling machines and featuring innovative operating panels is intuitive and easy to operate. Fully integrated into the machine control system, it enables a high degree of automation because important machine functions are directly linked to each other, guaranteeing precise milling results. In addition, **LEVEL PRO ACTIVE** offers a simple and field-tested 3D system interface with the 3D kit.

Numerous Additional and Automatic Functions

The **LEVEL PRO ACTIVE** leveling system offers many automatic and additional functions that make the operator's job easier. All of the connected sensors are displayed and can be selected on the control panel. This also speeds up work processes. This means the entire machine can be lifted quickly and easily to drive over a manhole cover, for example.

Optimized 3D and Laser Leveling

The drastically simplified method of attaching laser sensors to the cold milling machine's weather canopy makes it easier to use 3D systems.

Leveling Booms on the Right and Left With Sonic-Ski Sensor

The new leveling booms with Sonic-Ski sensor make the contactless scanning of a wire or a reference surface on both sides at a distance of up to 1,900 mm from the milling edge possible. In this context, the boom can be adjusted hydraulically from the operator's platform by up to 840 mm to the outside using the Sonic-Ski sensor during milling operation; and a mechanical adjustment offers an additional 880 mm of telescopic travel.

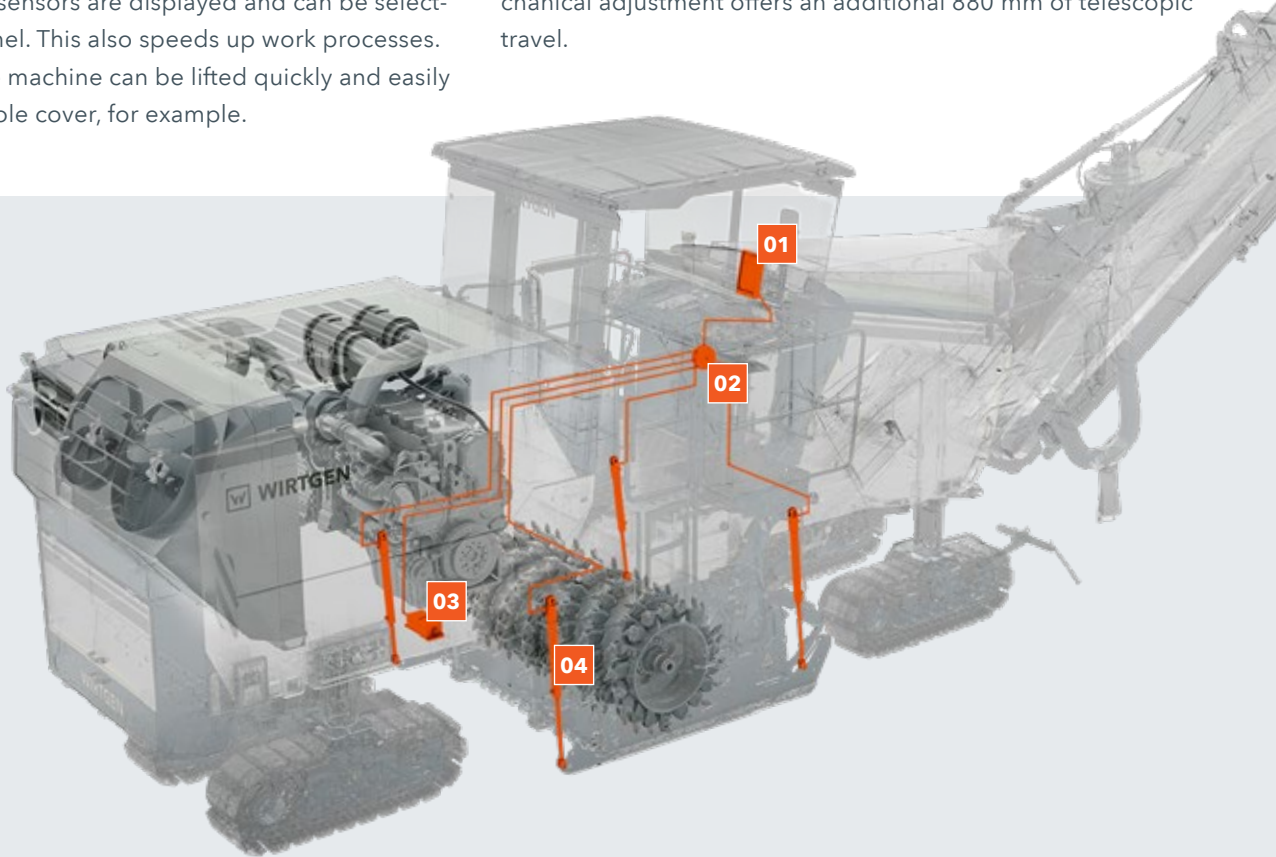

Optimized Multiplex System

The multiplex system consists of two ultrasonic sensors attached to flexibly adjustable swing legs on each side of the machine. Benefits of the system include the large adjustment range for a wide variety of leveling applications and the low weight of the individual units. The swing legs can be easily folded together onto the machine for machine transport.



01 Multiplex system with up to four ultrasonic sensors.

02 Scanning in front of the milling drum.

03 3D leveling / laser leveling.

04 Telescoping leveling boom.

— = Standard Equipment
 — = Optional Equipment

W 220 Fi with Standard Leveling Sensors

01 7" LEVEL PRO *ACTIVE* control panel

02 Machine control system

03 Cross-slope sensor

04 Hydraulic side plate cylinder with built-in displacement sensor

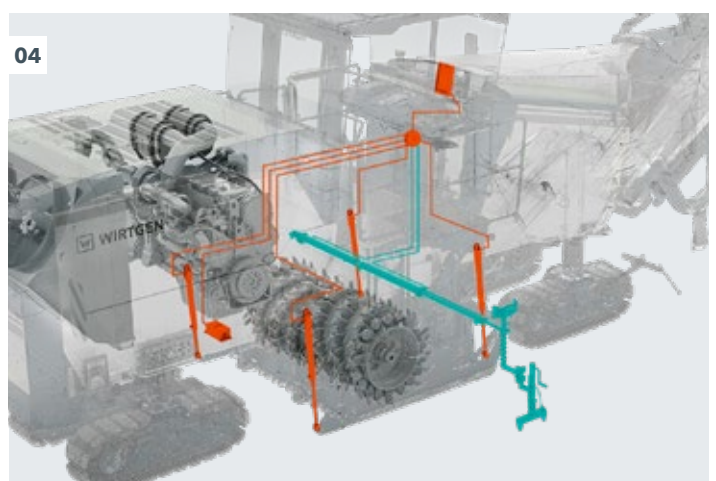
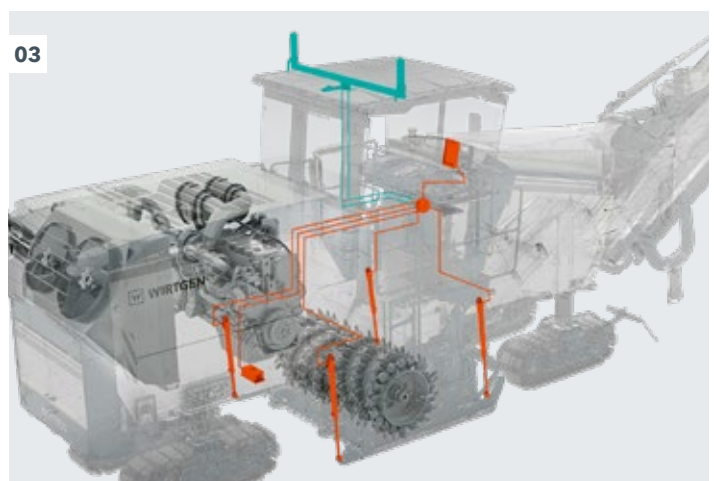
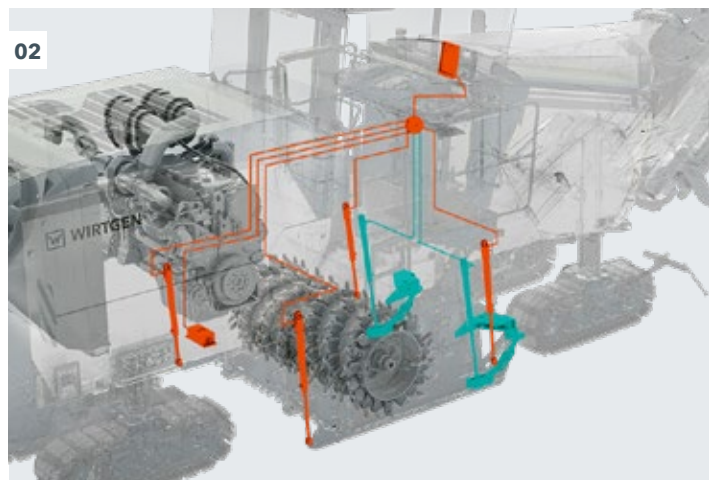
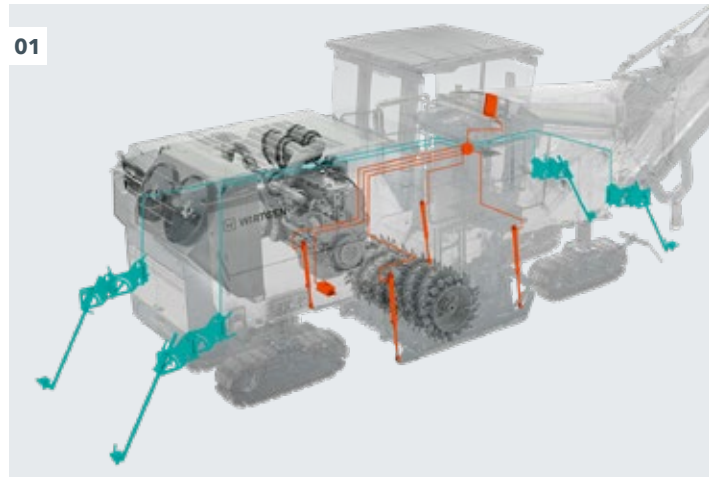

EXCEPTIONAL RELIABILITY

Groundbreaking Diagnostic Concept

The new diagnostic concept guides the operator easily and intuitively through the troubleshooting process. Any potential malfunction is clearly indicated to the operator on the display, including a description of the fault. The operator can then locate the malfunction using optimized, easy-to-understand color graphics. Finally, detailed assistance in writing ensures that the operator can begin to correct the error.

Redundant Machine Control

Three control computers built into the machine can be interchanged variably in order to ensure that the machine is always operational in the event that one of the three computers fails. In addition, the two 7" control panels on the operator's platform and outside for ground crews can be interchanged variably while maintaining all of the machine's functions.



Simple Fault Remediation

Detailed diagnostics info

Reliable Operation

CAN bus with backup circuits

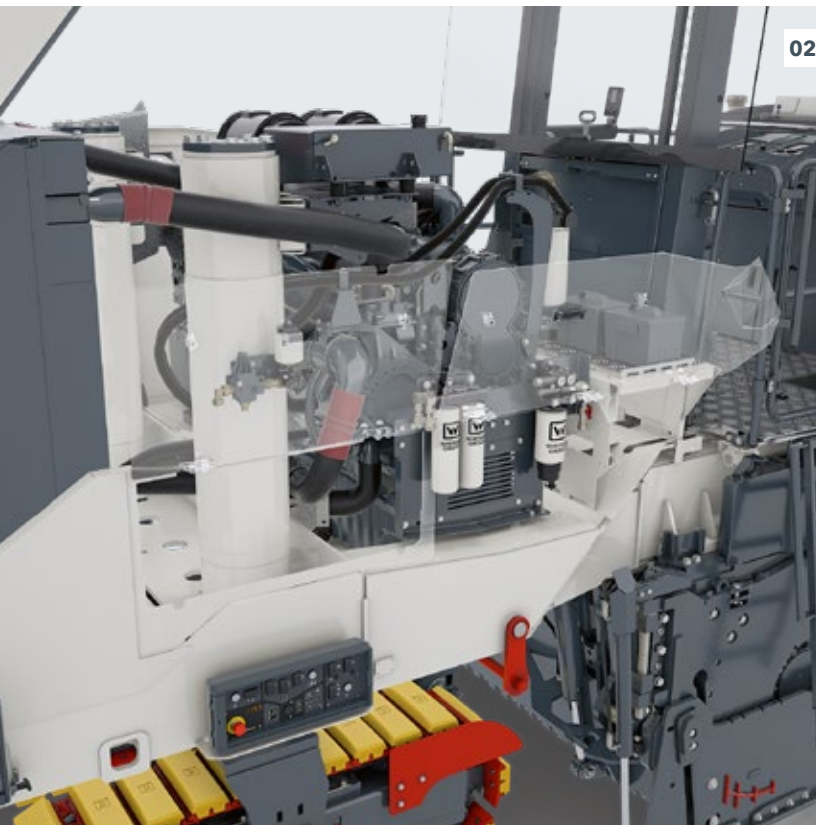

02



03



01

Robust, Reliable CAN Network

A backup CAN bus has been installed in important areas and can be switched to if necessary. The main control elements are equipped with two-channel signal transmission, meaning that they can still be used if one signal fails. Information about a signal failure is also displayed to the operator.

Reliable Vandalism Protection

The innovative vandalism protection system protects the control panels against the use of force or theft. This means that the control panels on the left and right side of the operator's platform can simply be pushed into the main control panel and locked. The linearly arranged control panels on the operator's platform can be folded and secured by means of a special mechanism via the

centrally positioned control panel. All in all, the simple method of securing the control panels also makes it possible to quickly prepare the machine for transport.

Time-Saving Service and Maintenance Concept

The W 220 Fi stands out thanks to significantly simplified access to the service points. As such, the air, hydraulic oil, and engine oil filters are all easily accessible from the operator's platform when the engine cover is open, for example. The diesel particulate filters are readily accessible from the ground for maintenance. In addition, all relevant machine components are quickly and easily accessible.

01 Images are directly forwarded from the error message to the diagnostics with clear localization.

02 Easy access to the service points, shown here on the W 220 Fi.

03 Secure and fast protection of control panels.

ONE-OF-A-KIND CUTTING TECHNOLOGY

Rapid Milling Drum Changes Thanks to MCS BASIC

Milling drums can now be changed even faster thanks to the new generation of MCS milling drums. The milling drum rotation device can be used to release just one central screw at the push of a button. The only thing the operator has to do afterwards is simply pull out the milling drum. The MCS side panel can be opened quickly and effortlessly using the hydraulic cylinder drive. This simplified process has many advantages: Rapidly changing milling drums with different tool spacings to meet specific application requirements increases machine productivity.

Changing the milling drum at short notice and using the ideal drum for the job reduces wear costs. In addition, this systems guarantees maximum flexibility for the ever-changing requirements during day-to-day operations.

Simple Milling Drum Assembly Changes

The new quick-change milling drum assembly allows different milling widths of 2.2 m, 2.5 m, 3.5 m, or 3.8 m to be selected. With the help of the simplified quickchange system, milling drum assemblies of different working widths can be changed in less than an hour. The significantly increased stroke of the

With Ease

Easy-to-swap milling drums

Wider Working

Additional milling units for greater width

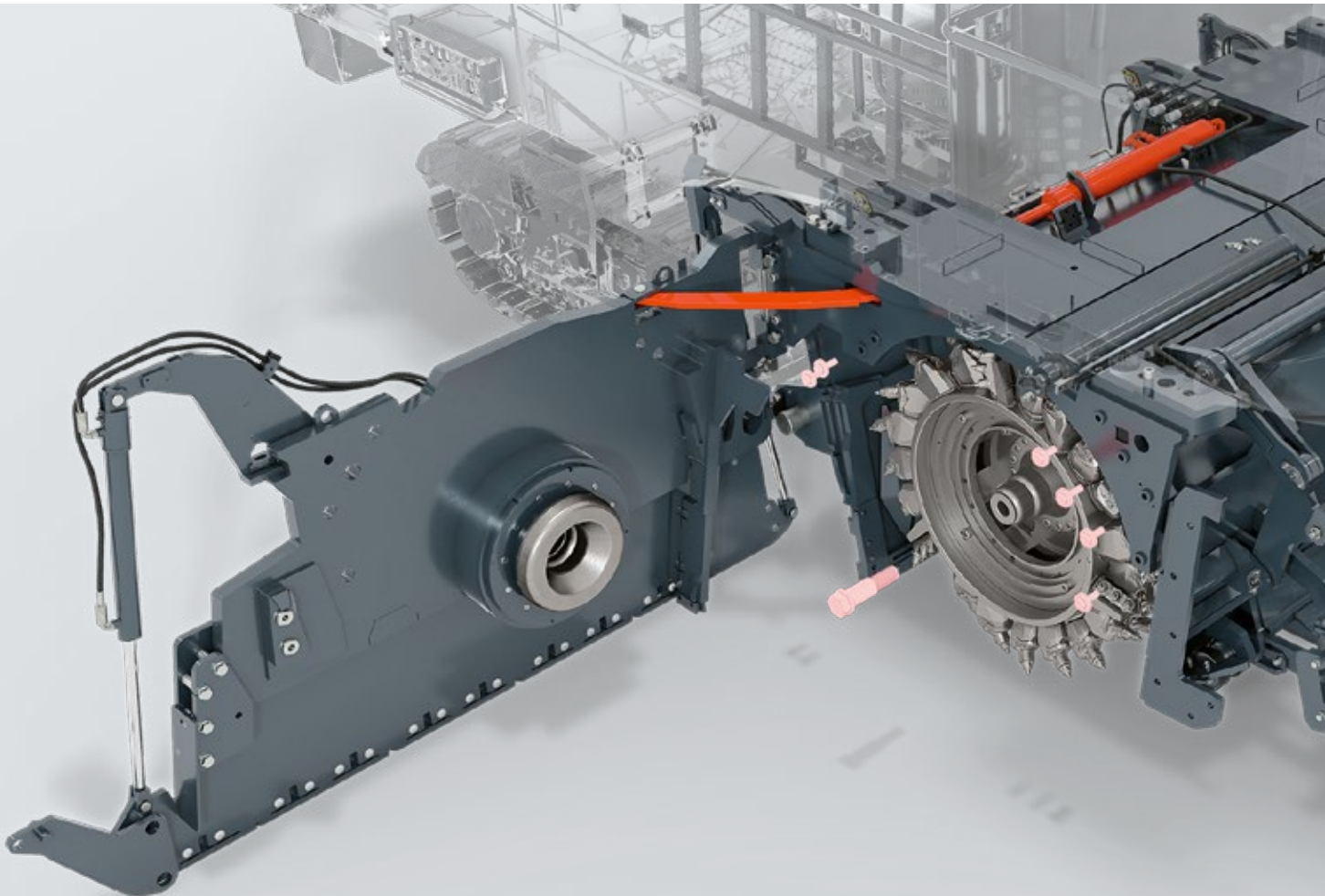

- 01 Milling drum changes are now even faster with the new **MCS BASIC** milling drum system.
- 02 Large selection of different MCS milling drums.

machine height adjustment makes work much easier. In addition, only one electrical plug connection, four hydraulic quick couplings, and one water hose need to be connected.

WIRTGEN > GOOD TO KNOW



Easy retrofit of ECO-Cutter milling drum results in reduced cutting resistance and therefore a drop in diesel consumption and CO₂ emissions.

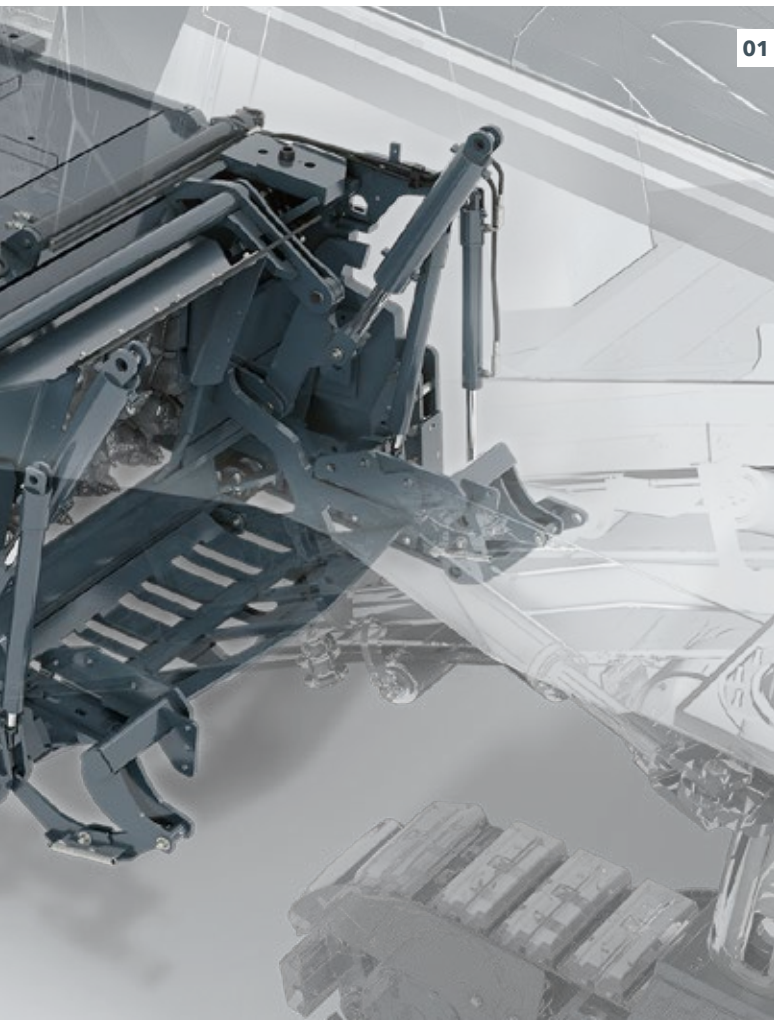

01



02

ECO-Cutter

Milling width: 2,200 mm, Milling depth: 0 - 350 mm, Tool spacing: 25 mm



Standard Milling Drum

Milling width: 2,200 mm, Milling depth: 0 - 350 mm, Tool spacing: 18 mm



Standard Milling Drum

Milling width: 2,200 mm, Milling depth: 0 - 350 mm, Tool spacing: 15 mm



Fine Milling Drum

Milling width: 2,200 mm, Milling depth: 0 - 100 mm, Tool spacing: 8 mm



Micro-Fine Milling Drum

Milling width: 2,200 mm, Milling depth: 0 - 30 mm, Tool spacing: 6 x 2 mm

ONE-OF-A-KIND CUTTING TECHNOLOGY

Optimized Protection against Milling Drum Assembly Wear

The side plates are equipped with extremely wear-resistant protective skids on both sides. Additional optional rollers attached to the side plates prevent scratches on the asphalt. In addition, the material depressor on rollers gently glides over the surface.

Extremely Wear-Resistant HT22 Quick-Change Toolholder System

The milling drums of the W 220 Fi are equipped with the HT22 quick-change toolholder system, making them perfect for highly demanding milling tasks. In addition, the heavy-duty milling drum design enables the upper parts of the quick-change toolholders to be changed quickly on site, if required.

01 Extremely wear-resistant HT22 quick-change toolholder system.

02 2,2 m, 2,5 m, 3,5 m und 3,8 m milling drum assemblies.

New HT22 PLUS Toolholder Upper Part with Increased Service Life

The new HT22 PLUS quick-change toolholder upper part features innovative centering marks on the tool contact surface. In combination with the new X² generation of picks, this reduces toolholder wear by up to 25% and also optimizes the rotation behavior of the picks. The new upper part offers considerable benefits such as higher milled surface quality and longer intervals between changes.

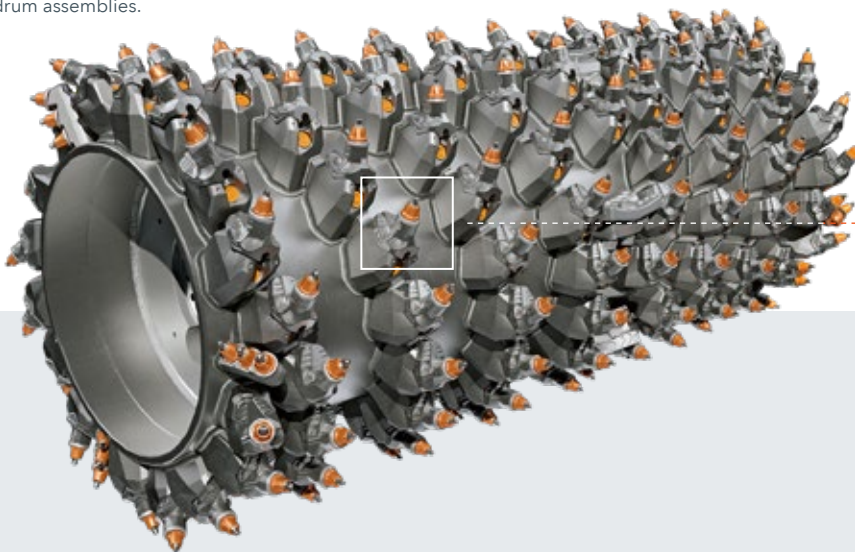

W 220 Fi with 2.2 m milling drum assembly

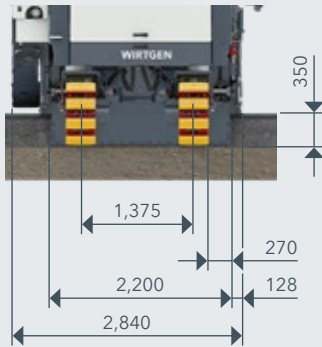

Standard Milling Drum

Milling width: 2,200 mm, Milling depth: 0 - 350 mm, Tool spacing: 15 mm

W 220 Fi with 2.5 m milling drum assembly

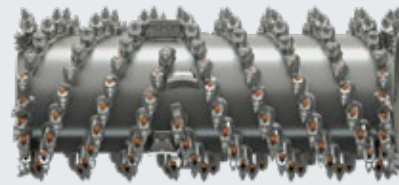
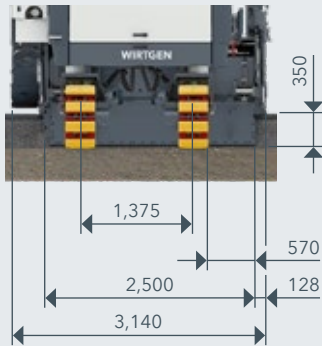

Standard Milling Drum

Milling width: 2,500 mm, Milling depth: 0 - 350 mm, Tool spacing: 15 mm

W 220 Fi with 3.5 m milling drum assembly

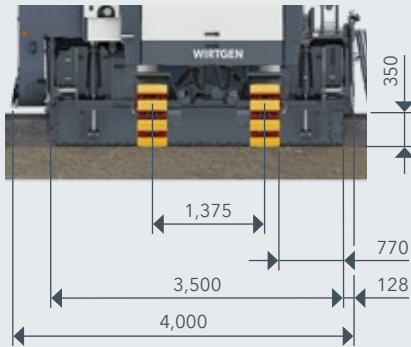

Standard Milling Drum

Milling width: 3,500 mm, Milling depth: 0 - 350 mm, Tool spacing: 15 mm

W 220 Fi with 3.8 m milling drum assembly

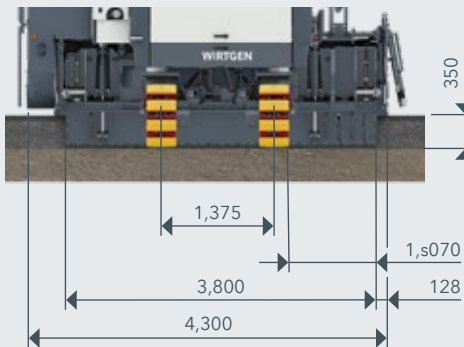

Standard Milling Drum

Milling width: 3,800 mm, Milling depth: 0 - 350 mm, Tool spacing: 15 mm

INNOVATIVE MILL ASSIST

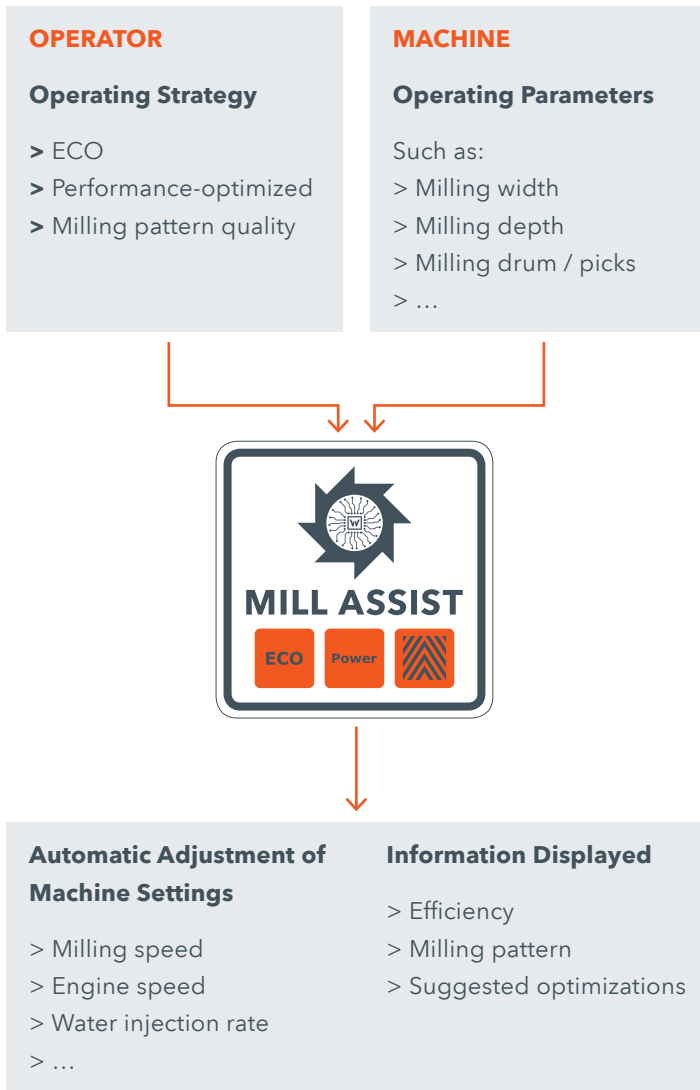

MILL ASSIST Automatic Mode

In automatic mode, the innovative **MILL ASSIST** machine control system always selects the operating strategy with the best balance between performance and costs. In doing so, the process optimization automatically adjusts the speed of the diesel engine and milling drum, the travel drive, the water system, and the machine's advance speed. This significantly reduces the operator's workload while improving machine



performance and considerably reducing diesel consumption, CO₂ emissions, and noise.

Additional Pre-Selection of an Operating Strategy in Automatic Mode

The operator can also pre-select one of three working strategies for the next application: "ECO", "performance-optimized" or "milling pattern quality." The machine then automatically adjusts the main parameters based on the selected operating strategy.

Clear Pre-Selection of Constant Milling Pattern Quality

The operator can preset the required milling pattern quality by simply pre-selecting from a scale from 1 to 10. This then automatically sets the milling drum rotation speed and the milling speed, taking the milling drum type into account.

MILL ASSIST

Efficient automatic milling

Three Strategy Presets

Optimal machine adjustment

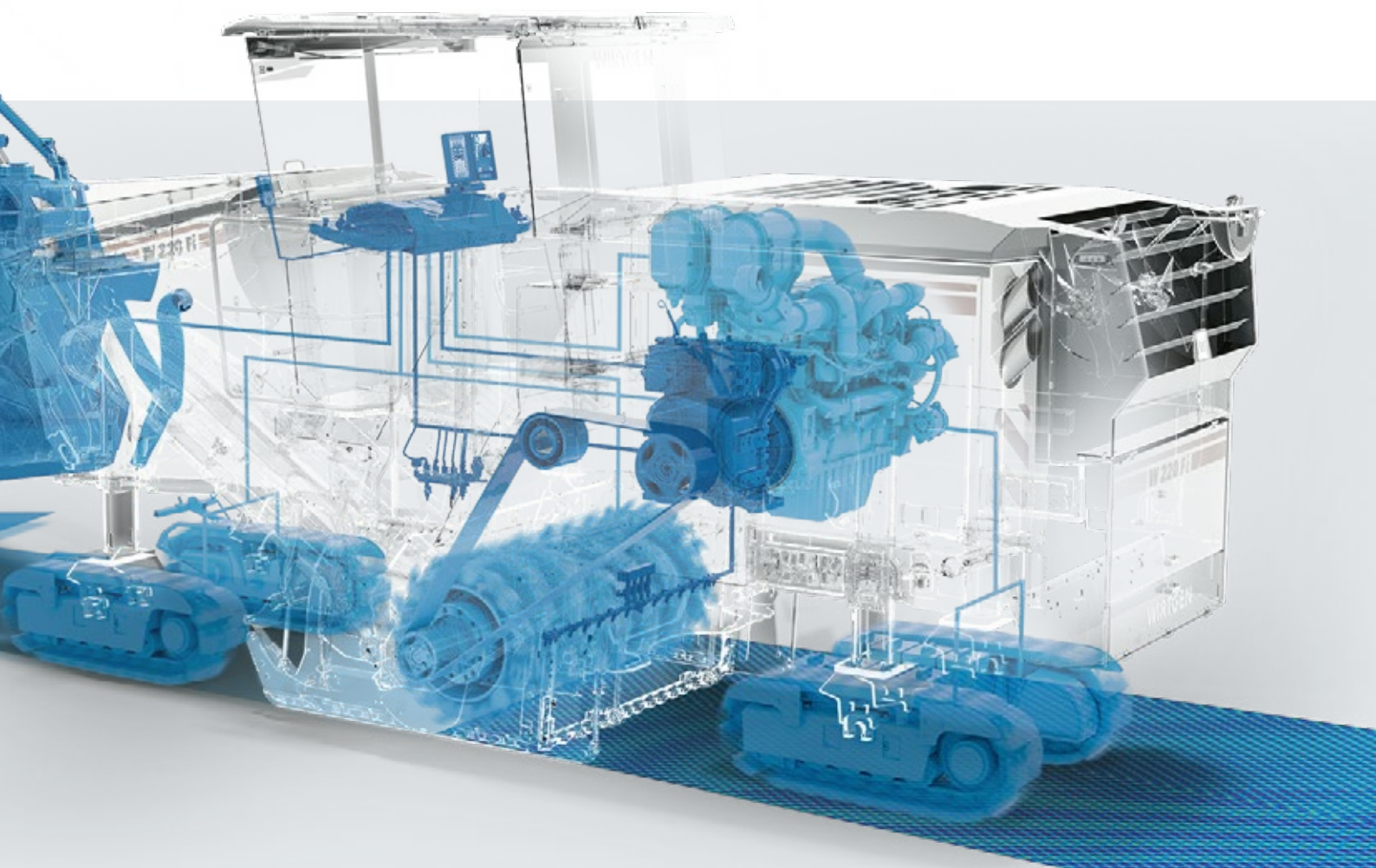
**Innovative Efficiency Indicator**

The machine operator can constantly monitor the machine's status via an efficiency indicator. Changes to the milling parameters that could potentially improve efficiency are also displayed on the control panel.

New DUAL SHIFT Powershift Transmission

The new two-speed **DUAL SHIFT** selector gearbox controlled via **MILL ASSIST** can also be shifted under load. **DUAL SHIFT** offers an extremely wide range of milling drum speeds and makes the machine perfect for a wide range of cost-effective milling applications. Low milling drum speeds reduce diesel consumption. High milling drum speeds make it possible to achieve maximum milling speeds during fine milling, for example.

WIRTGEN > GOOD TO KNOW

The **MILL ASSIST** machine control system in the W 220 F(i) enables efficient engine speeds while also boosting productivity. In particular, this results in a significant reduction in CO₂ emissions per cubic meter of milled material.

MAXIMUM MILLING PERFORMANCE



W 220 Fi cold milling machine engine characteristics

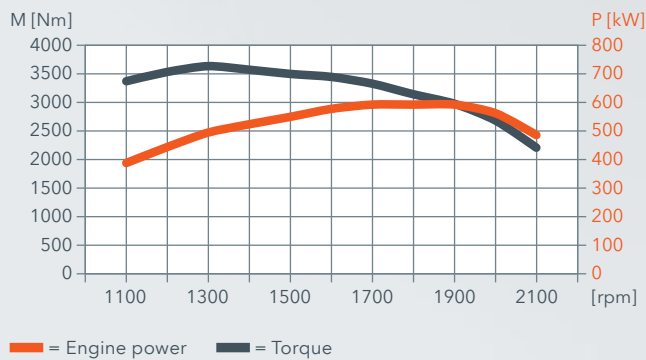

More Power

High-performance diesel engine

Optimized Transport

Removable additional weight

Powerful Diesel Engine

The engine's enormous power combined with its high maximum torque makes the machine even more powerful and versatile.

Increased Ballasting Flexibility

The additional weights weighing 1,500 kg can be quickly and easily installed or removed from the rear of the machine in two increments. This allows the desired machine transport weight to be adjusted even more precisely.



MAXIMUM MILLING PERFORMANCE

Large Scraper Lift with High Setting Depth

The increased scraper lift makes greater milling depths possible and thus expands the machine's range of applications when milling without material loading. This also allows a milling depth of up to 310 mm to be achieved as soon as the machine enters the position to begin milling. At the same

time, reduced material accumulation minimizes wear on the milling drum housing and the milling drum. Different scraper contact pressure levels can also be selected quickly and conveniently at the touch of a button via the 7" control panel, depending on the requirements and application.

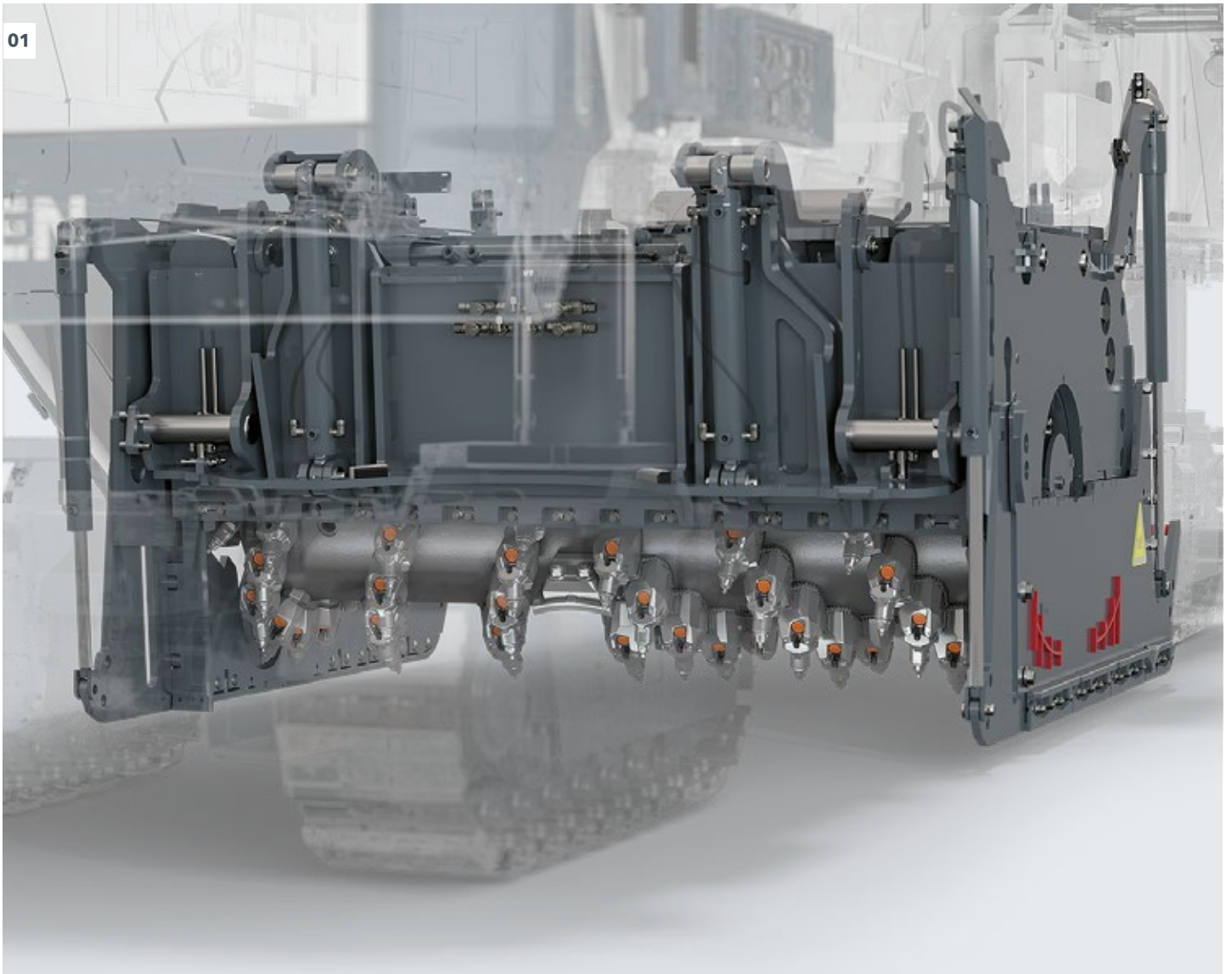

Precise and Flexible Loading

Two swing speeds plus large slewing angle

Fast and Flexible in Curves

ACTIVE CONVEYOR

02

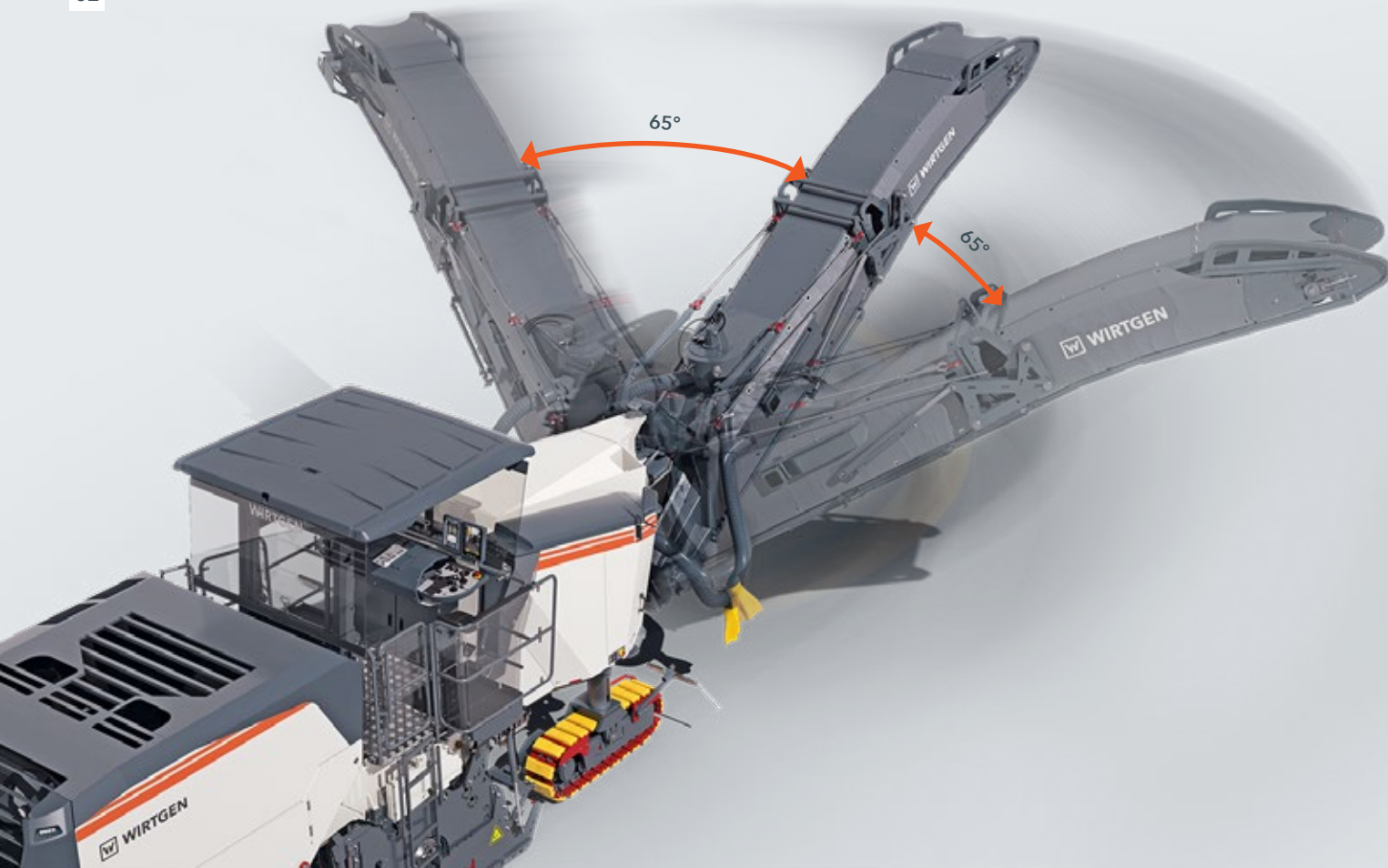

01 Increased scraper stroke for a wider range of milling applications and reduced wear. 02 The discharge conveyor has a large swing range.

Flexible and Powerful Loading of Milled Material

Extremely wide conveyor swing angles of 65° to both sides make it possible to load material even in difficult situations, e.g. in intersections or turning areas. Pressing the “Booster” button on one of the two main control panels temporarily increases the belt speed by 20% and the loading capacity of the discharge conveyor by 20% in order to temporarily transport milled material particularly high or far onto a truck bed. Two swing speeds, the belt speed that can be adjusted at the touch of a button, and the hydraulically folding discharge conveyor further increase flexibility on the job site.

ACTIVE CONVEYOR

When repositioning the discharge conveyor in difficult job site situations, the semi-automatic **ACTIVE CONVEYOR** swing angle control system assists the operator in the best possible way – such as when milling in intersections or bypassing road installations.

WPT - THE INFORMATIVE WIRTGEN PERFORMANCE TRACKER

Field-Tested WITOS FleetView Telematics System

The WITOS FleetView telematics system consists of the control unit (TCU) with a GPS receiver and a license to use the WITOS FleetView web application. The web interface provides a compact overview of the machine status with consumption data, operating hours, position data, error messages, and service intervals.

Optional Additional Equipment WPT for Clear Documentation of Milling Performance

The additional equipment WPT also tracks the machine's actual milling performance and provides consumption and position data in a clear, automatically generated report. Milling cross-sections measured by a laser scanner are converted for the purpose of calculating the milling volume. The current

Comprehensive job data

Site reports via email

Simple Accounting

No extra costs for surveying

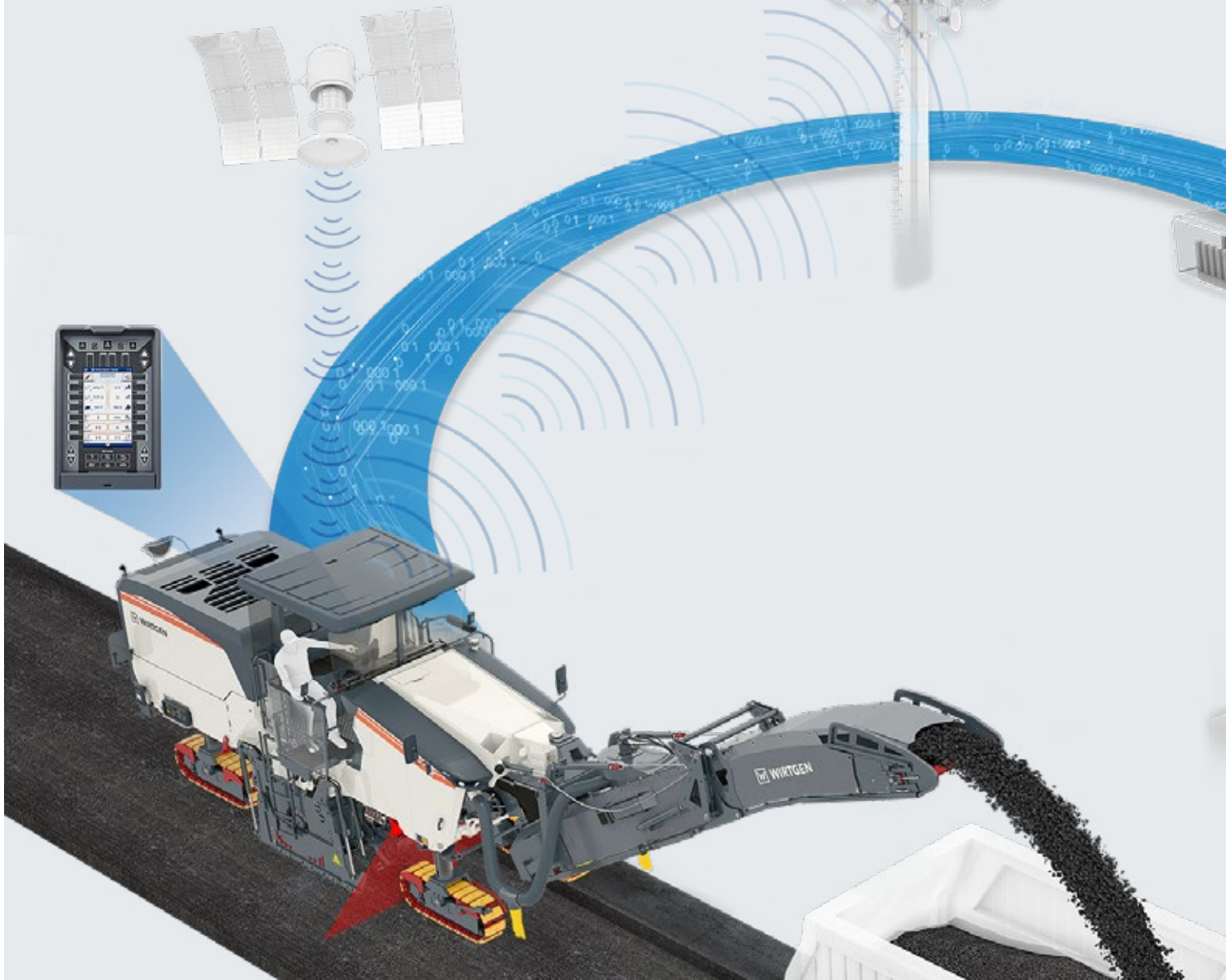

- 01 The operator is always aware of the current machine and application parameters - at the end of the workday, the data is transmitted to the machine owner.
- 02 The actual, currently active milling width is scanned by a laser scanner and clearly displayed on the operating panel.

milling volume and truck tonnage are constantly displayed to the operator on the 7" control panel during the milling process.

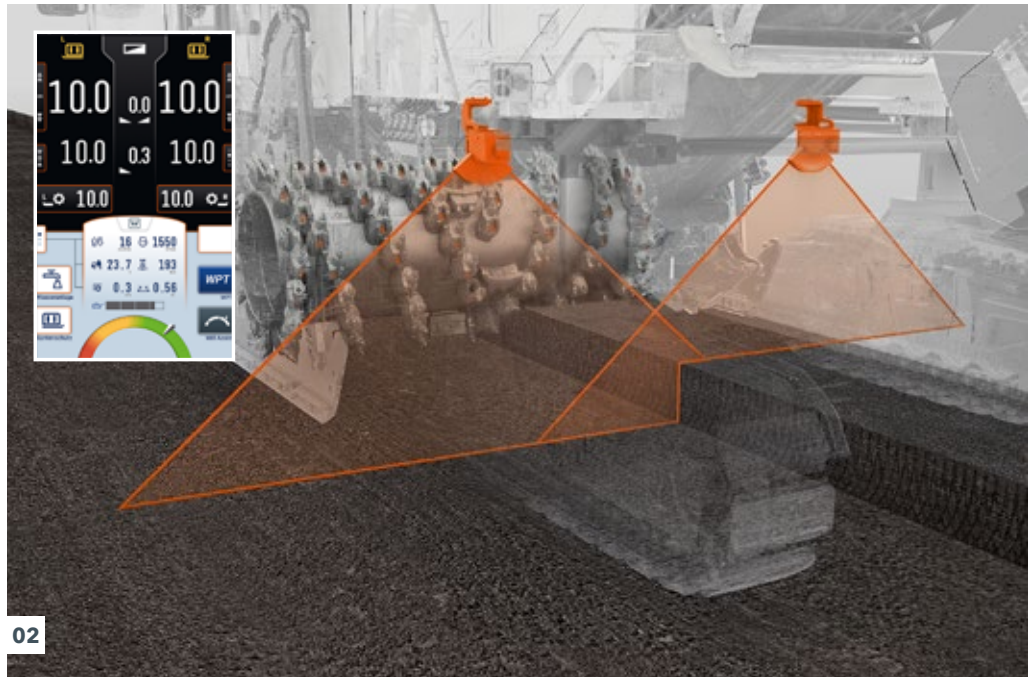

02



01

Automatically Generated Site Survey Reports

Milling performance data is continuously transmitted to a data server via a cellular connection. After completing a milling job, a site survey report is automatically generated in both Excel and PDF formats and sent by e-mail to the machine operator's job management office, for example. The site survey report contains precise information on the milling volume, milled area, and milling depth with the corresponding GPS position.

Job Site Tracking via Satellite Map Display

The site survey reports contain easy-to-read satellite map images detailing the completed milling work. In this context, the milled areas are shown in different colors based on the various milling depth classes.

Documentation of Consumables

The site survey report contains valuable information on consumables such as diesel, water, and picks. Information such as the number of loaded trucks is also displayed, if confirmed by the machine operator. This makes it possible to calculate operating costs quickly and easily.

REDUCED DIESEL CONSUMPTION - ACTIVE MINIMIZATION OF CO₂

01



WIRTGEN
SUSTAINABILITY

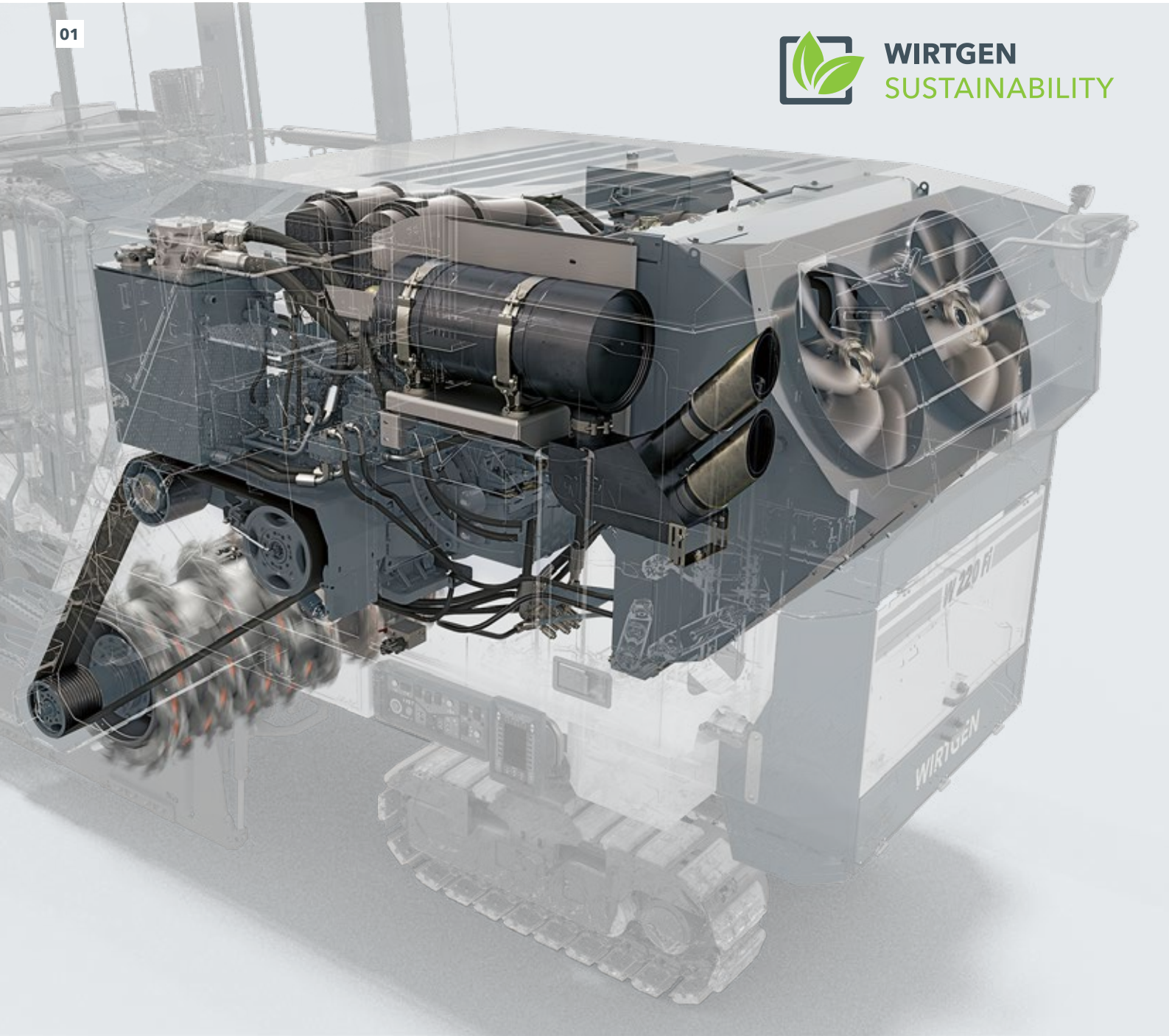

Continuously Efficient Engine Speed

Innovative DUAL SHIFT powershift transmission

Fuel-Efficient Cooling

Dual fan controlled by engine speed

02

WIRTGEN W 220 Fi Cold Milling Machine with Two-Speed DUAL SHIFT Powershift Transmission

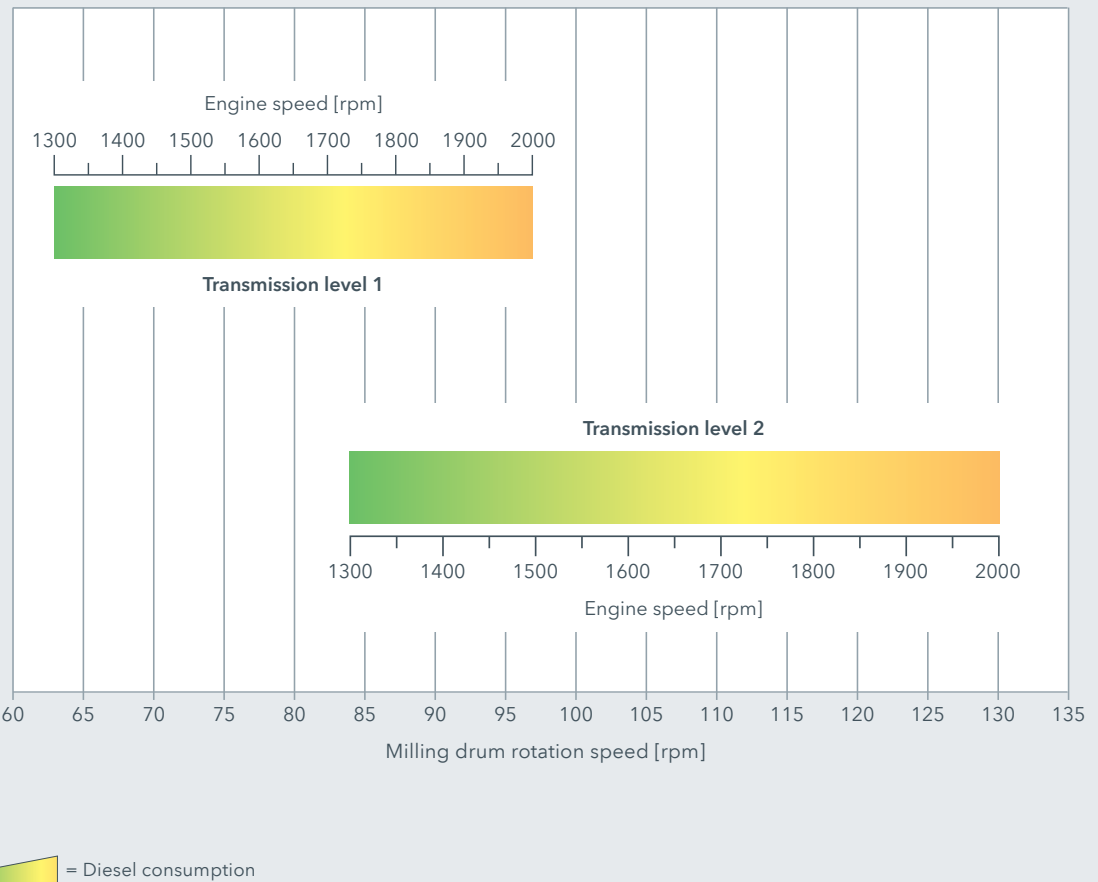

01 Compact engine drive station, shown here on the W 220 Fi.

02 Significantly expanded range of milling drum speeds for reduced diesel consumption and tool wear, shown here for the W 220 Fi.

Two-Speed Powershift Transmission for a Wide Range of Usable Milling Drum Speeds

The new two-speed **DUAL SHIFT** powershift transmission makes it possible to operate the machine at efficient engine speeds while maintaining powerful milling drum speeds. **DUAL SHIFT** offers the unbeatable advantages of low diesel consumption, reduced noise emissions, and unmatched milling performance.

Automatic Stop Feature for the Diesel Engine

The diesel engine is automatically switched off in idle mode after an appropriate cooling time. The engine stopping time is displayed on the control panels during the cooling phase.

Maximum Performance in the Low Speed Range

The built-in **MILL ASSIST** machine control system ensures that the diesel engine of the W 220 Fi primarily runs at lower speeds while simultaneously delivering high performance and low diesel consumption.

Automatic Start-Stop Feature of the Milling Drum

The start-stop feature temporarily switches off the milling drum after a few seconds when the milling operation has stopped, like when waiting for a truck, further reducing diesel consumption. The milling drum is then automatically switched on again when milling is resumed.

Intelligent Dual Fan Concept

Two separate speed-controlled and intelligently positioned fans cool the diesel engine and hydraulic system as required. As a result, the cooling system also helps efficiently reduce diesel consumption.

WIRTGEN > GOOD TO KNOW

All of the cutting-edge features of the W 220 F(i) listed above lead to a significant increase in sustainability.

ENVIRONMENTALLY FRIENDLY MACHINE TECHNOLOGY

Environmental Focus

Low CO₂ emissions

Minimal Water Usage

Efficient water metering



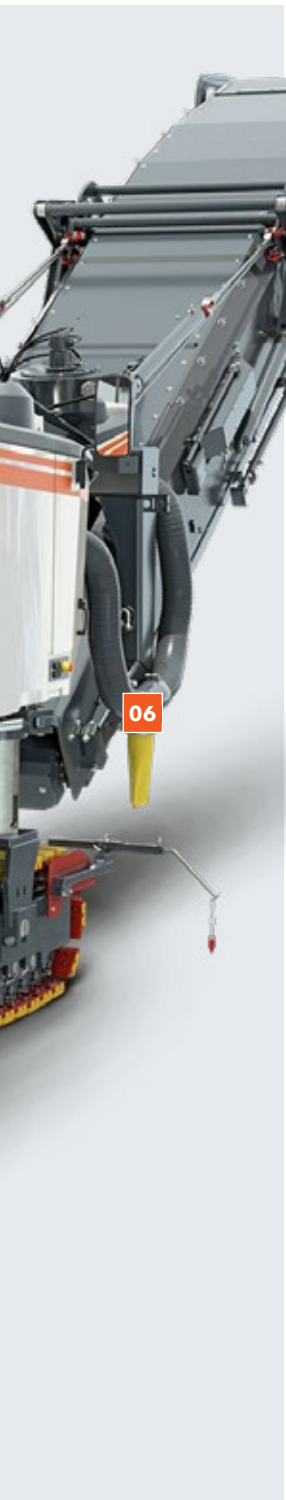

01 **Maximum Exhaust Gas Purification for Low Exhaust Emissions**

The state-of-the-art, fuel-efficient diesel engine of the W 220 F(i) offers maximum engine power with exceptionally high torque. In this context, the engine technology used in the W 220 F(i) meets the strict requirements of the highest EU Stage 5 emissions standard for minimum exhaust emissions.

02 **Reduced Noise Emissions During Relocation**

The cold milling machine has a travel speed of up to 88 m/min. At the same time, only low engine speeds are required - with reduced diesel consumption and lower noise emissions.

03 **Start-Stop Engine Function via External Control Panel**

The diesel engine can also be switched on and off effortlessly by ground crews via the external control panel, making it possible to further reduce diesel consumption and noise emissions.

04 **ECO Operating Strategy for Minimal Consumption**

Following selection of the ECO operating strategy, the **MILL ASSIST** machine control system reduces fuel consumption and pick wear and lowers noise emissions.

05 **Efficient Water Management**

Four separate water spray bar segments that can be activated electrically from the operator's platform allow the optimum amount of water to be added to the milling process, such as when milling only half the width of a lane. Automatic activation and deactivation of the water system as well as water injection on the basis of milling performance considerably reduce water consumption.

06 **Optimized VCS Extraction System**

VCS improves air quality and visibility in the machine operator's and ground crew's working area. In addition, the optimized design of the more easily accessible VCS suction channel reduces the amount of cleaning required.

WIRTGEN > GOOD TO KNOW



All of the features of the W 220 F(i) listed above help actively protect the environment and conserve natural resources.

SUSTAINABLE INNOVATIONS FOR A GREEN FUTURE

Today, it is more important than ever to minimize harmful CO₂ emissions on road construction sites - while still maintaining high levels of performance and productivity. Innovative WIRTGEN technologies play an active role in protecting the environment and conserving natural resources.

The W 220 Fi from the F-series - the current generation of large milling machines from WIRTGEN - cuts CO₂ emissions during operation by significantly reducing fuel consumption per cubic meter of milled material.

WIRTGEN > GOOD TO KNOW

Compared to the previous model - the W 220 from 2010 - the W 220 Fi reduces CO₂ emissions by as much as 20% per cubic meter of milled material. WIRTGEN innovations such as **MILL ASSIST**, **DUAL SHIFT** power shift transmission, and dual fan cooling all play a vital role here.

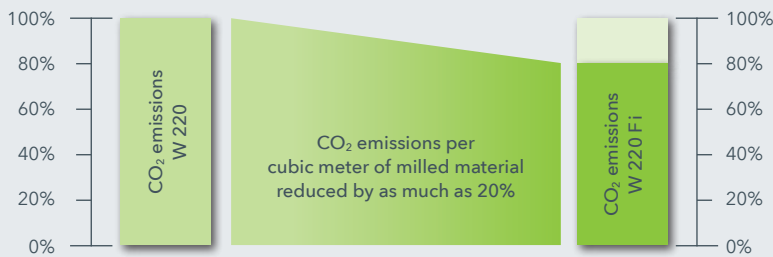

WIRTGEN W 220 (2010)

WIRTGEN W 220 Fi (2020)

As an HVO-ready machine, the W 220 Fi offers potential for further reductions in CO₂ emissions when run on the high-quality biofuel HVO.





WIRTGEN SUSTAINABILITY



The heavy-duty cold milling machine handle a wide range of applications, from surface layer rehabilitation to complete pavement removal and fine milling. Rapid milling drum assembly changes and particularly fast milling drum changes for milling widths of 2.2 m, 2.5 m, or 3.8 m thanks to the MCS (Multiple Cutting System) further expand the machine's wide range of applications. Thanks to the unique **DUAL SHIFT** powershift transmission with extended milling drum speed, the W 220 Fi is the perfect choice for particularly demanding milling tasks.



TECHNICAL SPECIFICATIONS W 220 Fi

Milling Drum

Milling width	2,200 mm
Milling depth ¹⁾	0 - 350 mm
Cutting diameter	1,140 mm

Engine

Manufacturer	Caterpillar
Type	C18 ATAAC
Cooling	Water
Number of cylinders	6
Rated power at 1,950 rpm	597 kW / 801 hp / 812 PS
Maximum power at 1,700 rpm	597 kW / 801 hp / 812 PS
Displacement	18.1 l
Fuel consumption at rated power during a mixture of job site operations	150 l/h 60 l/h
Sound power level in accordance with EN 500-2 engine operator's platform	≤ 113 dB(A) ≥ 80 dB(A)
Emissions standard	EU Stage 5

Electrical System

Power supply	24 V
--------------	------

Tank Capacities

Fuel	1,300 l
Hydraulic oil	120 l
Water	4,150 l

Driving Performance

Max. travel and milling speed	0 - 88 m/min (5.3 km/h)
-------------------------------	-------------------------

Crawler Units

Crawler units front / back (L x W x H)	2,000 x 370 x 750 mm
--	----------------------

Loading of Milled Material

Belt width of primary conveyor	1,100 mm
Belt width of discharge conveyor	1,000 mm
Theoretical capacity of discharge conveyor	552 m ³ /h

TECHNICAL SPECIFICATIONS W 220 Fi

Base Machine Weight

Empty weight of machine without fluids	34,400 kg
Operating weight, CE ²⁾	37,100 kg
Maximum operating weight (full tanks, full range of equipment) in FB2200	43,900 kg

Weight of Tank Contents

Water	4,150 kg
Fuel (0,83 kg/l)	1,080 kg

Additional Weight

Operator and Tools

> Machine operator	75 kg
> 5 pick containers	125 kg
> Vehicle tool kit	30 kg

Optional Milling Drum Units Instead of Standard

> Milling drum housing MCS BASIC FB2200	650 kg
> Milling drum housing MCS BASIC FB2500	1,650 kg
> Milling drum housing MCS EXTEND FB3500	3,500 kg
> Milling drum housing MCS EXTEND FB3800	4,500 kg

Optional Milling Drums Instead of Standard

> Milling drum FB2200 HT22 PLUS LA18 with 156 picks	-210 kg
--	---------

Optional MCS Milling Drums Instead of Standard

> Milling drum MCS BASIC FB2200 HT22 PLUS LA15 with 180 picks	100 kg
> Milling drum MCS BASIC FB2200 HT22 PLUS LA18 with 156 picks	-110 kg
> Milling drum MCS BASIC FB2200 HT22 LA15 with 18 standard picks and 162 PCD tools	150 kg
> Milling drum MCS BASIC FB2500 HT22 PLUS LA15 with 196 picks	390 kg
> Milling drum MCS EXTEND FB3500 HT22 PLUS LA15, multi-part, with 294 picks	2,020 kg
> Milling drum MCS EXTEND FB3800 HT22 PLUS LA15, multi-part, with 314 picks	2,450 kg

Optional Additional Equipment

> Operator's platform with functional stand-up seat, large storage compartment	80 kg
> Operator's platform with functional stand-up seat, large storage compartment, and weather protection canopy	600 kg
> Operator's platform with a high-quality comfort cabin	850 kg
> Two additional weights with a total weight of 1,500 kg	1,500 kg
> Large storage compartment at the rear of the machine for 72 pick containers	200 kg
> Extension of MCS BASIC with a hydraulically opening side panel for FB2200 / FB2500	50 kg
> VCS extraction system	140 kg
> Extension of LEVEL PRO ACTIVE with leveling booms and one Sonic Ski sensor	80 kg
> Extension of LEVEL PRO ACTIVE with two ultrasonic sensors for multiplex scanning	40 kg
> Extension of LEVEL PRO ACTIVE with four ultrasonic sensors for multiplex scanning	80 kg

¹⁾ The maximum milling depth may deviate from the value indicated due to tolerances and wear.

²⁾ Machine weight, half-full tanks, vehicle tool kits, machine operator, excluding optional equipment.

SIDE VIEW / TOP VIEW W 220 Fi

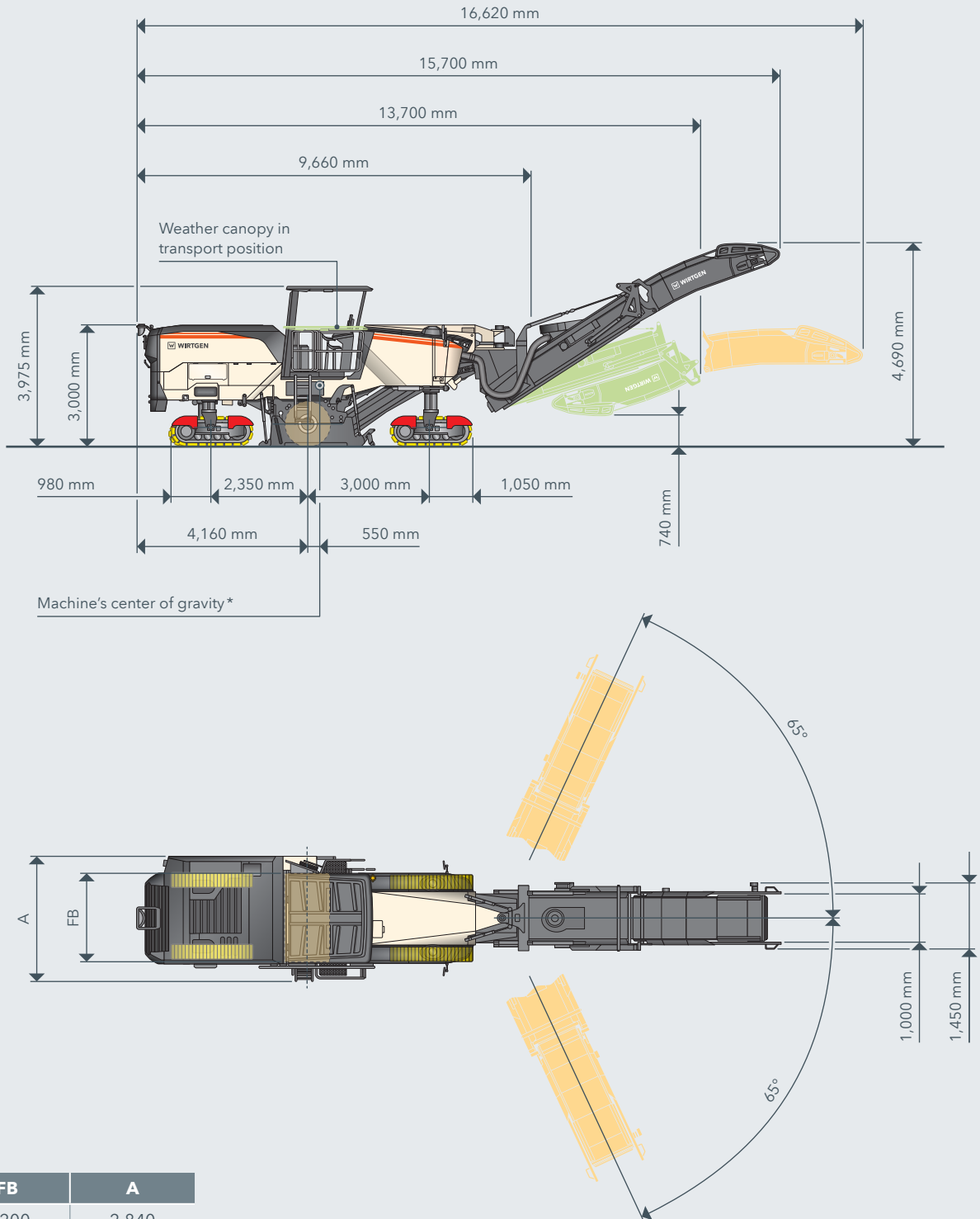

FB	A
2,200	2,840
2,500	3,140
3,500	4,000
3,800	4,300

*Based on operating weight, CE with conveyor folded out

MILLING RADIUS W 220 Fi AT MILLING DEPTH OF 150 MM

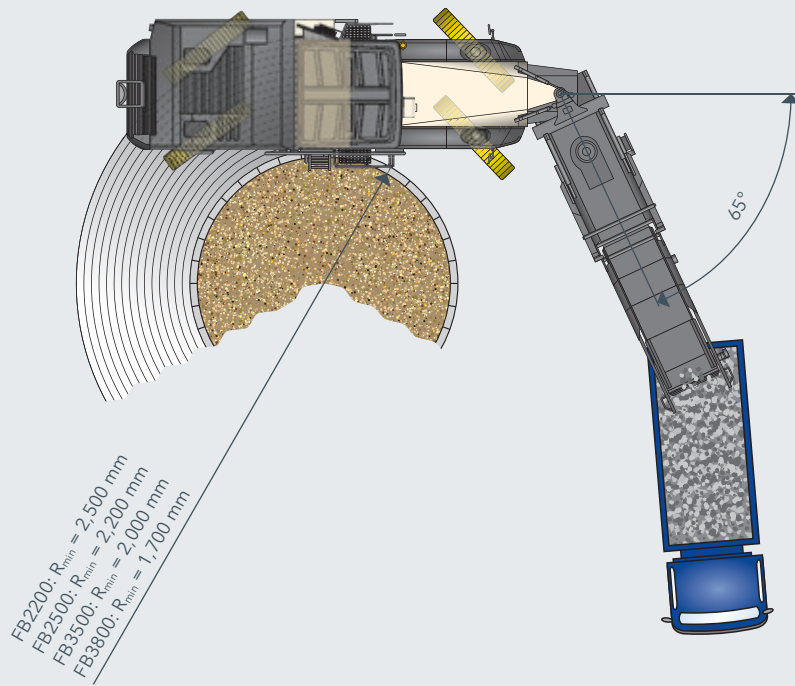
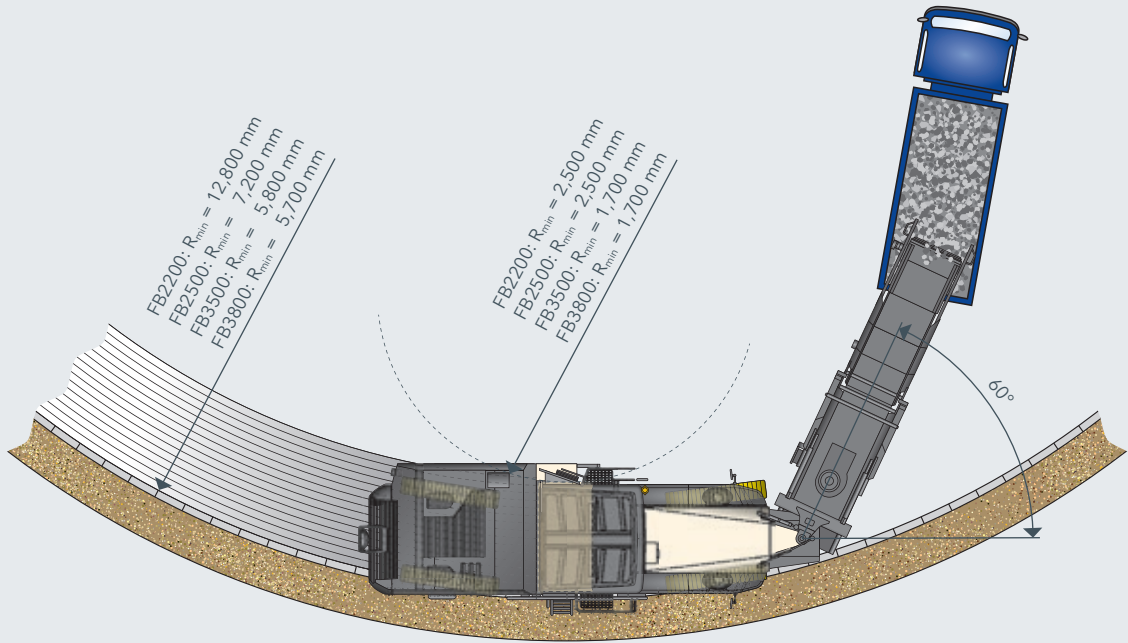

STANDARD EQUIPMENT W 220 F i

Basic Machine

- > Base machine with engine ■
- > Machine frame featuring a single wasp waist at the rear right and a dual wasp waist at the front ■
- > **DUAL SHIFT** two-speed powershift transmission for efficient engine speeds combined with powerful milling drum speeds ■
- > Automatic pressure adjustment of the hydraulic pump for cylinder functions in accordance with performance requirements for reduced diesel consumption ■
- > Hydraulically opening, soundproof engine cowling ■
- > Air compressor system ■
- > Battery-operated hydraulic unit for auxiliary drive ■
- > Two cooling fans to minimize power consumption of the cooling system ■

Milling Drum Unit

- > Adjustment of material depressor contact pressure via the control panel or automatically via the **MILL ASSIST** feature to reduce chunk formation ■
- > Electrical adjustment of scraper contact pressure via the control panel ■
- > Automatically controlled locking feature of scraper ■
- > Milling drum rotation device with electro-hydraulic milling drum drive for slowly turning the milling drum during pick replacement ■
- > Single-piece water spray bar in the milling drum unit for reliable pick cooling and to prevent dust development ■
- > Automatic control of the water quantity via the **MILL ASSIST** feature ■
- > Height adjustment stroke increased by 200 mm to facilitate pick replacement and the exchange of milling drum units ■
- > Pre-fitting to allow the quick exchange of milling drum units ■
- > Hydraulically lifting side plates, clearance right 450 mm, clearance left 330 mm ■
- > Milling drum housing FB2200 □

Milling Drums

- > Milling drum FB2200 **HT22 PLUS** LA15 with 180 picks □

Loading of the Milled Material

- > Increased conveyor swing angles of 65° each to the left and right ■
- > Discharge conveyor with adjustable conveying speed and two slewing speeds for precise loading ■
- > Boost feature for a temporary increase of the belt speed and conveying performance of the discharge conveyor by 20% ■
- > Water spray system in the primary conveyor ■
- > Larger conveyor pump for a constant belt speed even at a low engine speed of 1,300 rpm ■
- > Discharge conveyor, 8,150 mm long, 1,000 mm wide, with hydraulic folding device □

Machine Control and Levelling System

- > User-friendly control panel including 7" colour screen ■
- > **LEVEL PRO ACTIVE** levelling system with numerous automated and complementary operator relieving features ■
- > **LEVEL PRO ACTIVE** - automatic height control in transport mode ■
- > **LEVEL PRO ACTIVE** - ramp milling and auto-start feature for the second milling cut ■
- > **RAPID SLOPE** cross-slope sensor for **LEVEL PRO ACTIVE** levelling system ■
- > **MILL ASSIST** assistance system for automatic adjustment of the milling drum speed in accordance with the main area of application and the parameters selected in terms of engine load, advance rate, milling volume and quality of the milling pattern ■
- > Automatic start-stop feature of the milling drum to reduce diesel consumption ■
- > Comprehensive machine diagnostics on the control panel including, for example, a diagnostic system for the CAN bus ■
- > Voltmeter integrated into the control panel for voltage measurement in the event of a malfunction ■
- > Two control panels for operating functions performed by ground crew ■

STANDARD EQUIPMENT W 220 F i

Operator's Platform

> Convenient access to the operator's platform, left and right	■
> Anti-vibration mounted operator's platform across the full width of the machine including fold-out railing, right	■
> Electrical control cabinet on the operator's platform for optimum accessibility and fast troubleshooting	■
> Electrical level indicator for the water tank on the external control panels	■
> Time display on the main control panel and on the exterior control panels	■
> Two mirrors at the front, one mirror at the rear of the machine	■
> Operator's platform with functional stand-up seat	□

Track Unit and Height Adjustment

> PTS - automatic alignment of the machine parallel to the pavement surface	■
> ISC - intelligent track speed control including hydraulic four-track drive	■
> Fourfold full-floating axle for high machine stability	■
> High travel speed of up to 88 m/min at low engine speeds (1,350 rpm), reduced diesel consumption and low noise emissions	■

Miscellaneous

> "Welcome-and-Go-Home-Light" feature in the area of the operator's platform and access	■
> Large storage compartment on the machine for pick containers	■
> High-pressure water system with automatic on/off function, 18 bar, 67 l/min	■
> Good accessibility to all maintenance points on the engine station	■
> Pneumatic hammer with pick extractor/insertor	■
> Large tool kit in lockable tool box	■
> A total of six EMERGENCY STOP switches in appropriate positions on the machine	■
> Pre-fitting for installing the WITOS FleetView control unit	■
> European type certification, EuroTest mark and CE conformity	■
> Water tank filling from rear of machine	□
> Standard film coating in RAL 9001 (cream)	□
> WITOS - professional telematics solution for machine operation and service optimisation	□
> Standard LED lighting system with 19,700 lumens	□

■ = Standard equipment

□ = Standard equipment, can be replaced with optional equipment if desired

□ = Optional equipment

OPTIONAL EQUIPMENT W 220 Fi

Milling Drum Unit

> Milling drum housing FB2200	<input type="checkbox"/>
> Milling drum housing MCS BASIC FB2200	<input type="checkbox"/>
> Milling drum housing MCS BASIC FB2500	<input type="checkbox"/>
> Milling drum housing MCS EXTEND FB3500	<input type="checkbox"/>
> Milling drum housing MCS EXTEND FB3800	<input type="checkbox"/>
> Active floating position for the side plates, left and right	<input type="checkbox"/>
> Extension of MCS BASIC with a hydraulically opening side door for FB2200 / FB2500	<input type="checkbox"/>
> Electrically switchable sectional water spray bar for FB2200	<input type="checkbox"/>
> Electrically switchable sectional water spray bar for FB2500	<input type="checkbox"/>
> Electrically switchable sectional water spray bar for FB3500 / FB3800	<input type="checkbox"/>
> Wear protection rollers for side plates, left or right	<input type="checkbox"/>
> Mounting aid for lifting out the primary conveyor when changing the milling drum unit	<input type="checkbox"/>
> Transport carriage for milling drum units from FB2200 to FB4400	<input type="checkbox"/>
> Milling drum mounting and transport carriage FB1500 to FB2500	<input type="checkbox"/>
> Transport roller set for simplified milling drum unit change (FB1500 - FB3800)	<input type="checkbox"/>
> Quick-change milling drum unit FB2200 MCS BASIC	<input type="checkbox"/>
> Quick-change milling drum unit FB2500 MCS BASIC	<input type="checkbox"/>
> Quick-change milling drum unit FB3800 MCS EXTEND	<input type="checkbox"/>

Milling Drums

> Milling drum FB2200 HT22 PLUS LA15 with 180 picks	<input type="checkbox"/>
> Milling drum FB2200 HT22 PLUS LA18 with 156 picks	<input type="checkbox"/>
> Milling drum MCS BASIC FB2200 HT22 PLUS LA15 with 180 picks	<input type="checkbox"/>
> Milling drum MCS BASIC FB2200 HT22 PLUS LA18 with 156 picks	<input type="checkbox"/>
> Milling drum MCS BASIC FB2500 HT22 PLUS LA15 with 196 picks	<input type="checkbox"/>
> Milling drum MCS EXTEND FB3500 HT22 PLUS LA15, multi-part, with 294 picks	<input type="checkbox"/>
> Milling drum MCS EXTEND FB3800 HT22 PLUS LA15, multi-part, with 314 picks	<input type="checkbox"/>
> Milling drum MCS BASIC FB2200 HT22 PLUS LA8 with 297 picks	<input type="checkbox"/>
> Milling drum MCS BASIC FB2200 HT22 PLUS LA25 with 134 picks	<input type="checkbox"/>
> Milling drum MCS BASIC FB2200 HT5 LA6X2 with 740 picks	<input type="checkbox"/>
> Milling drum MCS BASIC FB2200 HT22 LA8 with 18 standard picks and 280 PCD tools	<input type="checkbox"/>
> Milling drum MCS BASIC FB2200 HT22 LA15 with 18 standard picks and 162 PCD tools	<input type="checkbox"/>
> Milling drum MCS BASIC FB2500 HT5 LA6X2 with 840 picks	<input type="checkbox"/>
> Milling drum MCS BASIC FB2500 HT22 PLUS LA8 with 335 picks	<input type="checkbox"/>
> Milling drum MCS BASIC FB2500 HT22 PLUS LA25 with 141 picks	<input type="checkbox"/>

Loading of the Milled Material

> Discharge conveyor, 8,150 mm long, 1,000 mm wide	—
> VCS extraction system	<input type="checkbox"/>
> Signal lights for visual “stop” and “go” instructions for the truck driver	<input type="checkbox"/>
> ACTIVE CONVEYOR swing angle control for discharge conveyor	<input type="checkbox"/>
> Support device for discharge conveyor	<input type="checkbox"/>

OPTIONAL EQUIPMENT W 220 Fi

Machine Control and Levelling System

> Actual milling depth measurement and display on the LEVEL PRO ACTIVE panel	<input type="checkbox"/>
> Overload sensors installed on the scraper	<input type="checkbox"/>
> 5" control panel for controlling the levelling system	<input type="checkbox"/>
> 7" control panel for displaying the machine control system and for controlling the levelling system	<input type="checkbox"/>
> Qty. 1 - 2" control panel including favourites buttons	<input type="checkbox"/>
> Qty. 2 - 2" control panels including favourites buttons	<input type="checkbox"/>
> User-specific storage of machine settings via SMART KEY key fob	<input type="checkbox"/>
> Extension of LEVEL PRO ACTIVE with levelling booms and one Sonic Ski sensor	<input type="checkbox"/>
> Extension of LEVEL PRO ACTIVE with one hydraulic sensor mounted on the right	<input type="checkbox"/>
> Extension of LEVEL PRO ACTIVE with two hydraulic sensors mounted on the left and the right	<input type="checkbox"/>
> Extension of LEVEL PRO ACTIVE with two ultrasonic sensors for multiplex scanning	<input type="checkbox"/>
> Extension of LEVEL PRO ACTIVE with four ultrasonic sensors for multiplex scanning	<input type="checkbox"/>
> Extension of LEVEL PRO ACTIVE with two ultrasonic sensors for multiplex scanning (FB3500 / FB3800)	<input type="checkbox"/>
> Extension of LEVEL PRO ACTIVE with four ultrasonic sensors for multiplex scanning (FB3500 / FB3800)	<input type="checkbox"/>
> Extension of LEVEL PRO ACTIVE with pre-fitting for 3D levelling for machines without canopy	<input type="checkbox"/>
> Extension of LEVEL PRO ACTIVE with pre-fitting for 3D levelling for machines with canopy	<input type="checkbox"/>
> Extension of LEVEL PRO ACTIVE with pre-fitting for 3D levelling for machines with cabin	<input type="checkbox"/>
> Extension of LEVEL PRO ACTIVE with two laser receivers	<input type="checkbox"/>

Operator's Platform

> Operator's platform with functional stand-up seat, large storage compartment	<input type="checkbox"/>
> Operator's platform with functional stand-up seat, a large storage compartment and weather canopy	<input type="checkbox"/>
> Operator's platform with a high-quality comfort cabin	<input type="checkbox"/>
> Warm air heating close to the operator's hands and feet	<input type="checkbox"/>
> Additional stand-up seat for operator's platform	<input type="checkbox"/>

Miscellaneous

> Hydraulically operated filling pump for water refilling	<input type="checkbox"/>
> Film coating according to the customer's wishes	<input type="checkbox"/>
> Model without WITOS	<input type="checkbox"/>
> Extended LED lighting system with 43,600 lumens	<input type="checkbox"/>
> High-performance LED lighting system with 93,600 lumens, including LED lighting balloon	<input type="checkbox"/>
> Two additional weights with a total weight of 1,500 kg	<input type="checkbox"/>
> Large storage compartment at the rear of the machine for 72 pick containers	<input type="checkbox"/>
> Storage compartment close to the rear track units for 10 pick containers	<input type="checkbox"/>
> Powerful high-pressure water cleaner, 150 bar, 15 l/min	<input type="checkbox"/>
> One hydraulic pick ejector	<input type="checkbox"/>
> Two hydraulic pick ejectors	<input type="checkbox"/>
> 2-fold camera system	<input type="checkbox"/>
> 4-fold camera system with 10" control panel	<input type="checkbox"/>
> 8-fold camera system with 10" control panel	<input type="checkbox"/>
> Dual starter system	<input type="checkbox"/>
> Electrical diesel suction and pressure pump including 7.50 m suction hose	<input type="checkbox"/>
> Licence plate holder with LED lighting	<input type="checkbox"/>
> Drawbar eye at the rear with a 50 kN load capacity	<input type="checkbox"/>

■ = Standard equipment

■ = Standard equipment, can be replaced with optional equipment if desired

□ = Optional equipment





**WIRTGEN GmbH**

Reinhard-Wirtgen-Str. 2
53578 Windhagen
Germany

T: +49 2645 131-0
F: +49 2645 131-392
M: info@wirtgen.com

 www.wirtgen.de



For further information, please scan the code.