



Technical specification

# Binding agent spreader SW 19 SC



# Technical specification / Technical description

	<b>Binding agent spreader SW 19 SC</b>
<b>Container</b>	
Container capacity	19.4 m <sup>3</sup>
Size of filling connector / filling hose	4"
<b>Conveyor chain</b>	
Width of conveyor chain	950 mm
Opening height of slide gate	350 mm
<b>Spreading unit (metering feeders)</b>	
Working width / Partial widths (standard)	2,460 mm / 3 x 820 mm
Working width / Partial widths (optional)	2,760 mm / 3 x 920 mm
Max. spreading quantity at 2 km/h and a powder density of 1 kg/l	62 kg / m <sup>2</sup>
<b>Engine</b>	
Engine manufacturer	Cummins
Cooling	Water
Number of cylinders	6
Max. power	242 kW / 325 HP
Rated speed in spreading mode	1,800 rpm
Displacement	8,900 cm <sup>3</sup>
<b>Travel characteristics</b>	
Travel speed	0.05 – 50 km/h
Turning radius (outside)	8.5 m
Ground clearance below the spreading unit	700 mm
<b>Weights</b>	
Empty weight*	18,900 kg
Max. permissible operating weight	45,000 kg
<b>Tyres</b>	
Tyre size	800 / 45 R 30.5
<b>Filling capacities</b>	
Fuel tank	300 l
Hydraulic fluid tank	200 l
<b>Dimensions</b>	
Dimensions for truck transport (L x W x H)	9,777 x 2,960 x 3,450 mm

\*1 = Basic machine without any additional equipment

**Binding agent spreader SW 19 SC**  
Dimensions in mm

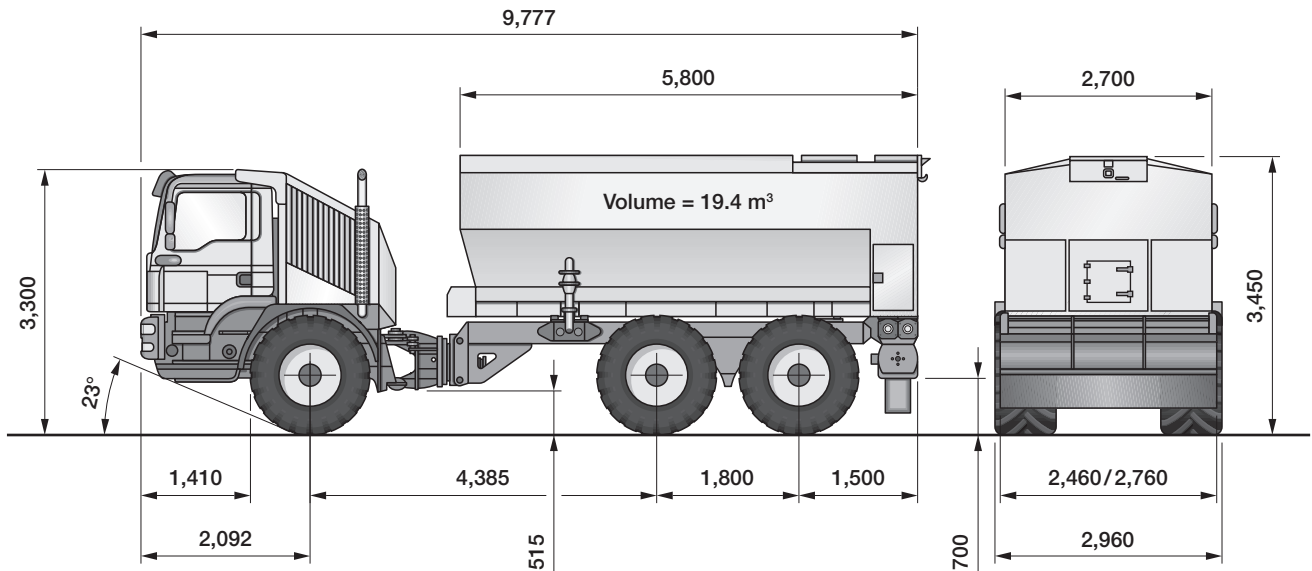

**Basic design**

Binding agent spreader in the SC class, built up on the "RHINO" trailer specially developed for difficult ground conditions. The spreading quantity is set at the spreader's on-board computer and is governed by the computer independent of the travel speed. The binding agent container and vehicle chassis are bolted together.

**Dimensions and weights**

- Overall length: 9,975 mm (including spreader)
- Overall width: 2,960 mm
- Wheelbase (1<sup>st</sup> axle – 2<sup>nd</sup> axle): 4,390 mm
- Overall height: 3,440 mm
- Ground clearance: 545 mm
- Ground clearance of rotors: 650 mm
- Empty weight: 18,900 kg (9,150 kg at the front axle; 9,750 kg at the rear axles)
- Travel speed: 0.05 to 50 km/h

**Chassis**

- Front chassis: sectional steel side members with integrated cross member to accommodate the front superstructure

- Rear chassis: box-type side members, connected to the articulated joint by means of two large bolts
- Articulated joint with a steering angle of up to 45°, operated via two double-acting hydraulic cylinders with priority function; turning radius R = 8.5 m
- Electric emergency steering pump (automatic operation in case of engine failure)
- Generously sized ball slewing ring with a diameter of 590 mm to allow free torsional movement between the front and rear vehicles
- Central lubrication system, make Lincoln
- Mechanical steering lock for transport
- Chassis painted in RAL 7015 (slate grey)

The chassis has been designed specifically for use in extreme working conditions and is dimensioned accordingly.

**Axles and suspensions**

- Three drive axles
- Pneumatic differential locks between the axles and wheels (inter-axle differential locks plus three inter-wheel differential locks)
- Vehicle operation possible in 6x2 as well as 6x4 or 6x6

# Technical description

- Pneumatically operated drum brakes at all six wheels
- Spring-loaded brake cylinder
- Independently suspended rear axles mounted by means of connecting rods
- Axle suspension front and rear by means of hydraulic cylinders (one cylinder per wheel)
- Electro-hydraulic slope correction system for the rear chassis

Multiple combination options of the differential locks, hydraulic suspension with extended suspension travel, as well as perfect load distribution ensure unparalleled traction on all types of ground.

## Wheels and tyres

- Low-pressure tyres 800 / 45 x 30.5, 16 PR (800 mm wide, 1,500 mm diameter) on reinforced rims with valve protection tube

The large footprint of the tyres provides the machine with good flotation properties.

Their self-cleaning, aggressive tread pattern guarantees excellent off-road capabilities.

## Engine

- CUMMINS QSL 19 TURBO DIESEL TIER 3
- Power: 242 kW (325 HP) at 2,100 min<sup>-1</sup>
- 6 cylinders, straight
- Bore x piston stroke: 114 x 145 mm
- Displacement: 8.9 litres
- Compression ratio: 17.8 : 1
- Cyclonic pre-cleaner type "Turbo 2"
- Generously dimensioned air filter
- Combined air / water cooler
- Compressor 31 m<sup>3</sup>/h at 8 bar
- Alternator 100 A – 24 V
- Fuel tank with a capacity of 300 litres and WIGGINS type quick-filling device
- Two vertical exhaust systems with exhaust pipe manifold facing outwards

## Manual gearbox

- Combined mechanical and hydrostatic transmission of power

- 1) Mechanical transmission in "travelling" mode
- 2) Hydrostatic transmission in "spreading" mode
- 8 forward gears and 4 reverse gears in each mode (i.e. a total of 16 forward speeds and 8 reverse speeds)
- Manual or automatic shifting of gears while driving
- Pneumatic switching to change from "travelling" mode to "spreading" mode (spreading is possible in "travelling" mode for small spreading quantities)
- Mechanical transmission: manual gearbox with separate torque converter (max. speed 50.7 km/h)
- Hydrostatic transmission: hydrostatic gearbox between manual gearbox and converter (0 to 15 km/h)

This combination offers both the convenience of automatic transmission during road travel and the possibility to move slowly and continuously in spreading mode, enabling large spreading quantities to be discharged.

## Hydraulic system

- Two pumps with variable flow rates for the steering and drive systems of the binding agent spreader
- Closed circuit for the travel drive system
- Hydraulic fluid tank with a capacity of 200 litres
- Suction filter 10 µ absolute
- Manual emergency operation of the hydraulic valve block

## Driver's cabin

- Cabin (RAL 9001), coil spring mounted, which can be tilted by means of lifting cylinders.
- Cabin equipment:
  - Heating and automatic climate control system
  - Particulate matter filter and pollen filter
  - Tinted safety glass windscreen
  - Washing and wiping system
  - Tinted side windows with electric window lifters
  - Air-sprung, adjustable comfort driver's seat
  - Compressed air connection in cabin
  - Static co-driver's seat, with longitudinal and backrest adjustment
- Safety belts
- Adjustable steering column
- Fully equipped dashboard

- Radio, CD
- Several storage compartments
- Electrically adjustable, large-angle rear view mirrors
- Lockable roof hatch
- ROPS safety roll bars

The spreader is equipped with a cabin in standard design offering proven ergonomics, high comfort, high-quality equipment features and good visibility.

An additional feature worth mentioning is the cabin's short overhang towards the front. A large angle of tilt permits convenient access to the mechanical components. In terms of accessibility, special emphasis was placed on ensuring that any cleaning and maintenance procedures can be completed with the greatest possible ease.

#### Lighting and signalling system

- Vehicle lighting
- Rear working lights mounted at the cabin roof
- Reversing alarm
- Two rotating beacons on the cabin roof
- One rotating beacon at the rear

#### High spreading accuracy with all types of dry free-flowing binding agents

Complies with the classifications in accordance with LTV 333 and the regulations in accordance with NF 9 98-115. Spreading quantity control in proportion to the spreader's travel speed by means of electronic quantity metering control. High discharge quantity in a single pass with a deviation in both longitudinal and transverse direction of less than 5%.

Permanently constant adherence to the specified spreading quantity regardless of the spreader's travel speed.

#### Binding agent container with a capacity of 19 m<sup>3</sup>, continuously welded, with interior bracing

All components are sandblasted as well as prime-coated and painted with high-quality two-component acrylic resin paints. Two 600 mm x 600 mm inspection ports (one inspection port in the upper section offering access to the container, and one inspection port in the rear section offering access to the spreading unit).

The inspection ports are equipped with an emergency stop

switch. Aluminium access ladder mounted on the container side. Binding agent container and chassis are bolted together.

#### Pneumatic filling device

Pneumatic high-speed filling device in flange design, size R 4", mounted on both sides of the container. Including coupling, shut-off valve, integrated stone sieve and air vent valve.

#### Large vent pipe (Ø 160 mm)

Integrated in the rear section of the container. The vent pipe ensures reliable forced deaeration of the container during filling. Two safety valves have been integrated on the top side of the container offering additional protection against excess pressure.

#### Filling level indicator for "container full" and "container empty"

"Container full" is indicated via an audible signal at the binding agent container. "Container empty" is indicated via a light signal at the control panel in the carrier vehicle.

#### On-board computer system

Consisting of an electronic programmable logic controller and control terminal with large display. The system enables precise discharge of the preselected spreading quantity in kg/m<sup>2</sup> even at varying travel speeds.

All machine functions are controlled by the PLC, which is installed in the machine's electrical cabinet. The machine is operated via the control terminal, which is placed inside the driver's cabin of the carrier vehicle. The terminal display keeps the driver informed of parameters such as the current spreading quantity in kg/m<sup>2</sup>, travel speed, hydraulic pressure, area completed, quantity spread, machine load, working width, container filling level, remaining distance or job data. The operation parameters of individual machine components are also visualized. Visual and audible alarms are generated as and when required.

#### Speed sensors

The machine's travel speed is detected by two different sensors:

# Technical description

The ground is scanned by a non-contact ultrasonic radar unit, which thus detects the slip-independent forward movement of the machine.

As the radar units are not suitable for scanning extremely smooth ground, or for travel speeds lower than 0.5 km/h, an additional sensor is installed at the cardan shaft.

The machine operator can conveniently choose between the two types of sensors at the control terminal.

## **Slide gate**

Hydraulically operated slide gate with an opening height of 350 mm. The slide gate is operated via the spreader's on-board hydraulic system and is controlled via the on-board computer (opens and closes automatically).

## **High-performance conveyor chain**

The fully yellow zinc plated conveyor chain consists of drop-forged chain links and conveyor flights.

It is controlled by the on-board computer, supplying binding agent to the filling shaft as required.

The conveyor channel has a width of 950 mm. Two variable hydraulic motors with planetary gearbox guarantee high conveying rates combined with tremendous efficiency. A cover plate located above the conveyor chain additionally reduces the load on the conveyor system.

## **Filling shaft**

Filling shaft with two integrated cross-feeding augers for permanent feeding of binding agent to the metering feeders.

The feeding augers ensure homogeneous circulation and even distribution of the binding agent across the full working width.

## **Spreading unit**

Special spreading unit consisting of three self-cleaning metering feeders with a diameter of 410 mm each which distribute the binding agent on the ground by means of a flexible cellular wheel.

The discharge quantity ranges from 5 to approx. 60 kg/m<sup>2</sup> at a travel speed of 2 km/h (assuming a powder density of 1.0 kg per litre). The working width is divided into three separately load-engageable partial widths.

Each partial width is driven separately via a special high-volume hydraulic motor (without leak-off pipe).

Correct discharge of the specified spreading quantity is ensured by means of permanent, electronically governed speed control.

## **Monitoring of spreading rate**

Collecting pan and digital suspended scales for check weighing.

## **Safety during transport**

Sturdy lashing lugs for secure lashing and a steering lock ensure safe transport of the machine on the flatbed truck.

## **Technical documentation**

In duplicate (on CD and in printed form)

Equipment features	SW 19 SC
<b>Container</b>	
Lockable side doors	○
Stone sieve for filling device	○
Loading and lashing lugs	○
<b>Drive system / Control system / On-board computer</b>	
Load-sensing hydraulic pump	○
Control terminal with graphic display	○
Radar unit	○
Reversing light, reversing alarm	○
Panorama rear view mirror	○
<b>Operator's cabin</b>	
Comfort seat, air-sprung	○
Air conditioning unit	○
Radio, CD	○
Collecting pan and digital suspended scales for check weighing	○
<b>Miscellaneous</b>	
Reversing colour camera	●
Printer for job data	●
Working lights	●
Electronic weighing device <sup>*1</sup>	●
WeighTronic <sup>*1</sup>	●
Dust protection cloth	○
Dust removal filter system to filter the vent air during the filling operation	●
Bag filter package for venting with filter connector and pressure relief flap	●
Compressed air storage system	○
Central lubrication system	○
Technical documentation	○

\*1 = Not calibratable

○ Standard ● Optional



Wirtgen GmbH  
Reinhard-Wirtgen-Strasse 2 · 53578 Windhagen · Germany  
Phone: +49 (0) 26 45/131-0 · Fax: +49 (0) 26 45/131-242  
Internet: [www.wirtgen.com](http://www.wirtgen.com) · E-Mail: [info@wirtgen.com](mailto:info@wirtgen.com)

Made by STREUMASTER Maschinenbau GmbH