

Tracked Paver

SUPER 700i



PERFECT IN EVERY CLASS

The right paver for any job

VÖGELE's seamless product range is considered unique in the industry. Whether a service road or a highway, an airfield or a race track, a new construction or a rehabilitation job, thick or thin, hot or cold - customers will find the right machine in our paver range for every paving task.



VÖGELE PRODUCT RANGE

MINI CLASS

- > Maximum paving width
10 ft. 6 in. (3.2 m)
- > Maximum laydown rate
275 tons/h (250 tonnes/h)

COMPACT CLASS

- > Maximum paving width
13 ft. 9 in. (4.2 m)
- > Maximum laydown rate
385 tons/h (350 tonnes/h)

UNIVERSAL CLASS

- > Maximum paving width
19 ft 6 in (5.95 m)
- > Maximum laydown rate
770 tons/h (700 tonnes/h)

HIGHWAY CLASS

- > Maximum paving width
32 ft (9.75 m)
- > Maximum laydown rate
1,200 tons/h (1,100 tonnes/h)

SPECIAL CLASS

- > SprayJet

HIGHLIGHTS

Perfectly equipped



DRIVE

01 Future-proof drive technology

- > Powerful and economical thanks to its 74 hp (55.4 kW) diesel engine and ECO mode.
- > Positive tracking and precise steering thanks to closed-loop traction drive.

OPERATING SYSTEM

02 ErgoBasic operating system

- > Simple operation with the innovative and easy-to-grasp ErgoBasic operating concept.

03 Niveltronic Basic automated system for grade and slope control

- > Easy-to-use system for automated grade and slope control.

MATERIAL MANAGEMENT

04 Mix intake

- > Optimal feeding thanks to large material hopper with 12,790 lbs. (5.8 metric tonnes) capacity.
- > Hydraulically adjustable asymmetric hopper wall for easier loading on confined jobsites.

05 Movable push roller

- > Facility to move the push roller to left makes material supply from trucks easier when paving along walls and other boundary structures.

OPERATION

06 Compact size

- > Small enough to operate in the tightest conditions.

07 Range of paving applications

- > Wide range of paving applications from 20 in. – 10 ft. 6 in. (0.5 – 3.2 m) for a large number of paving projects.

08 Screeds

- > The SUPER 700i delivers high levels of precompaction with both the AB 200 V and the AB 220 V.



01



02



03



04



05



06

SUPER 700i

Great things come in small packages

With its compact dimensions, variable pave width and powerful performance, the SUPER 700i is ideal for pavement repairs and paving small areas.

The SUPER 700i is a highly compact small paver suitable for a wide range of applications. Whether paving on narrow paths, close to walls and edges, between streetcar tracks, or inside buildings: the Mini Class demonstrates the full range of its capabilities specially when working in confined spaces.

The SUPER 700i is ideal for small and medium-sized jobs such as backfilling trenches or paving footpaths and cycle tracks. The SUPER 700i also brings its special qualities to bear in gardening and landscaping applications, as well as for paving inside halls

and underground parking garages, where machines need to be highly maneuverable and compact.

Its technology is a match for the large "Dash 3" pavers, featuring highly efficient material feed and the advanced ErgoBasic operating concept.

And last but not least, it also offers great value for money. That makes the SUPER 700i the ideal machine for small gardening and landscaping businesses and municipal services.



01 Large material hopper with 12,790 lbs. (5.8 metric tonnes) capacity.
02 Positive tracking and precise steering thanks to closed-loop traction drive.
03 Easy handling with the innovative user-friendly ErgoBasic operating concept.
04 All key paving functions can be controlled on the two handy screed remote control units.

05 Fully integrated Niveltronic Basic system for automated grade and slope control.
06 Can be combined with the AB 200 V and AB 220 V extending screeds.

PRECISION IN TIGHT SPACES

Paving up to within 2 in. (5 cm) of boundaries

The SUPER 700i operates wherever jobsites are very confined, narrow or low. Its compact size and great maneuverability make it the ideal machine for the purpose.

The Mini Class paver really comes into its own when working on highway medians, and inside underground parking garages, where its small size, great maneuverability and powerful performance are crucial for efficient operation.

The technically advanced Mini Class paver can handle even the toughest conditions. Its asymmetric hopper wall enables easy loading in very tight spaces, for example.



- 01** With an outer track gauge of just 3 ft. 9 in. (1.14 m), the paver is ideal for paving between tramway rails and in milled strips.
- 02** Thanks to its track width of just 4 ft. 7 in. (1.4 m), it can easily fit through narrow driveways or gates. That means the paver is even able to pave vehicle traffic surfaces inside buildings such as underground parking garages with ease.

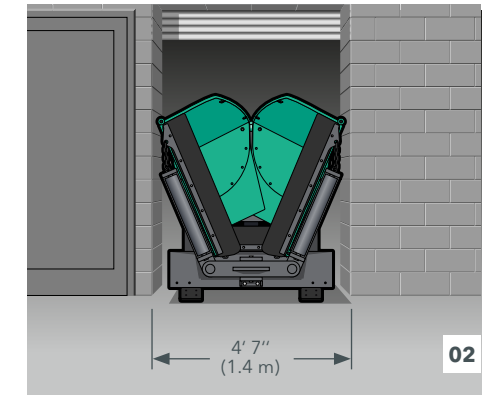
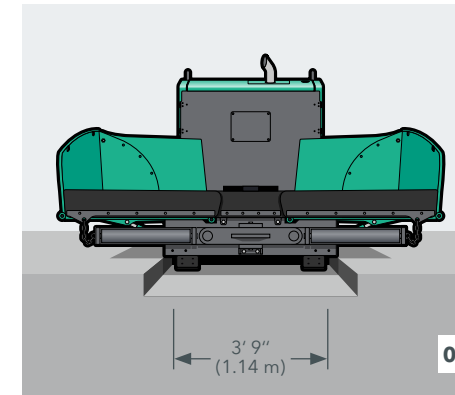

- 03** The well-thought-out paver design allows machine-based paving up to within 2 in. (5 cm) of boundaries. The overall height of less than 6 ft. 7 in. (2 m) allows paving in low spaces and under canopy roofs.
- 04** The great range of paving widths can be used in a wide variety of applications, ensuring high utilization of the machine.

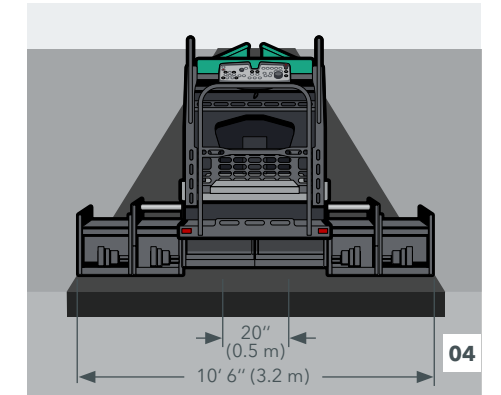
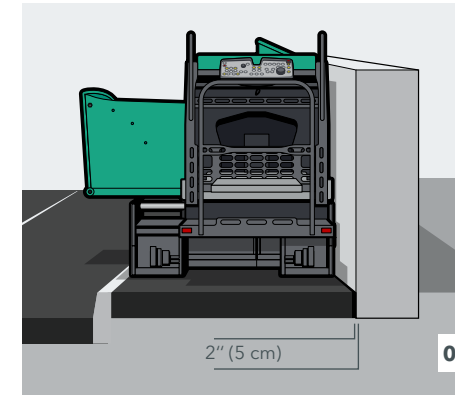

SEVERAL MATERIAL FEED OPTIONS AND OPTIMAL FLOW OF MATERIAL

Several feeding options are particularly important when space is narrow and confined. That is exactly what the large material hopper of the SUPER 700i was designed for. It can be conveniently supplied with material by truck or wheeled loader, depending on how much space is available.

The large material hopper with separately folding wings is designed so that the machine can always be supplied with paving material in the best, most cost-effective way. The optional asymmetrical hopper (left wing) allows the paver to be supplied with material by truck even if the feed vehicle is unable to dock centrally in front of the machine, as is the case when paving along walls or other boundaries, for instance.

The pavers of the Mini Class come with a powerful material handling system. The large material hopper holds an ample supply of material, while the wide conveyor tunnel permits a high material throughput. The large auger flights ensure that the material is spread evenly in front of the screed.

Material hopper with 12,790 lbs. (5.8 metric tonnes) capacity
with separately adjustable side walls for optimal feeding

Wide conveyor tunnel
allows for high mix throughput rates



- 01 Material hopper with 12,790 lbs. (5.8 metric tonnes) capacity
- 02 Reversible conveyor
- 03 Large material tunnel
- 04 Asymmetric hopper wall

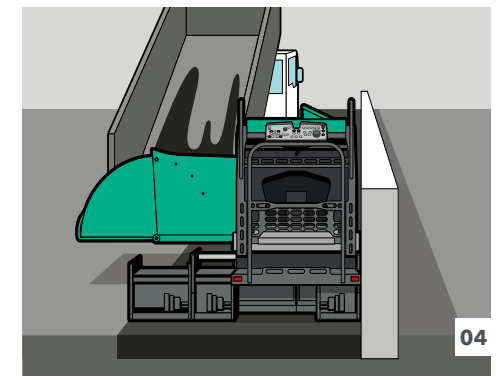
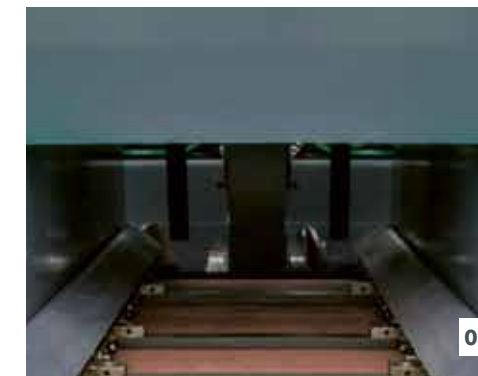

The arrangement of the conveyor drive at the rear of the machine makes for optimum power transmission, ensuring a high conveying capacity while minimizing wear of paver components. The conveyor is reversible, preventing any spills of material when repositioning the paver on the job site.

The conveyor tunnel is wide enough to guarantee a high material throughput of up to 275 tons/h (250 tonnes/h).

VÖGELE > GOOD TO KNOW

Height-adjustable spreading auger

The auger flights with 12 in. (30 cm) diameter ensure homogeneous distribution of the mix. The height of the spreading augers can be continuously adjusted by 4 in. (10 cm) - as an option even hydraulically.

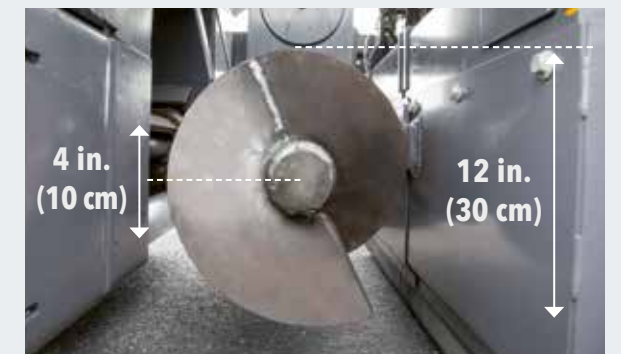



THE ERGOBASIC OPERATING SYSTEM

Full control for the driver and operator

The ErgoBasic operating concept was developed on the basis of the tried and tested ErgoPlus operating system, and specially adapted to the needs of Mini Class pavers. It focuses on the essential functions.

The aim was to develop an operating system with which our small machines can be operated just as quickly, precisely and intuitively as the large ones. That makes VÖGELE the only manufacturer to offer a standardized operating concept for all paver classes.



THE PAVER OPERATOR'S ERGOBASIC CONSOLE

Practical and neat

Everything at a glance: the functions are arranged in a clear, logical and practical layout. The type of controls and the symbols used are all in line with those of an ErgoPlus console but have been tailored to the functions of a small paver.

Given the limited number of functions, there is no need for a display. The status of all settings is indicated as a percentage on LED strips immediately next to the relevant functions.

Other LEDs show the set speeds of the auger and the compacting system, as well as the fill level of the diesel tank.



Safe operation during the night

Glarefree backlighting comes on automatically as darkness sets in, so that the paver operator can also work safely on night-time jobs.



01 Travel function group and status indicators

This groups together all the functions for driving the paver, together with machine status indicators.

02 Material Management function group

This is where the operation of the hopper walls, the conveyor and spreading auger is controlled.

03 Screed function group

This includes all the screed functions, such as the settings for the tamper bars and vibrators, and the controls to adjust the screed width and pitch.

TRAVEL AND STATUS INDICATORS

Function group 1

01 Choice of operating modes for the paver

The paver changes between operating modes at the push of a button in the following order: "Pave", "Positioning", "Job Site" and "Neutral". An LED indicates which mode is selected. On leaving "Pave" mode, the memory function stores all the last settings, which means that the paving parameters last used are retrieved immediately after repositioning the machine on the job site, for instance.

02 Steering with preselected steering angle

The machine is steered by means of a rotary controller which enables the paver operator to maneuver the machine precisely even in the tightest spots. For long curves with a constant radius, the desired steering angle can be preselected using arrow keys. The paver stays automatically on the set track until the function is deactivated, allowing the paver operator to monitor the paving process undisturbed.



- 01** The paver switches mode between Pave, Positioning, Job Site and Neutral at the push of a button.
- 02** For easy and precise maneuvering, the machine is steered using a rotary controller.



03 Function and status indicators

The function and status indicators mean that the operator always has full control over his machine, even without a display. He can, for instance, read the fill level of the fuel tank directly and identify whether there are any functional faults.

04 Choice of engine speed ranges

There are three speed ranges for the diesel engine: MIN, ECO and MAX. The desired range can be set easily using the arrow keys. Many construction projects can be completed in ECO mode. The lower engine speed reduces noise emissions considerably and saves on fuel.

MATERIAL MANAGEMENT

Module 2

01 Auger speed

In automatic mode, the maximum speed of the spreading augers can be adapted to the working width separately for the right and left by the plus and minus keys, without using ultrasonic sensors. The set value is displayed as a percentage on the LED strip.

02 Conveyor reversing

To avoid soiling by falling mix in Jobsite mode, such as at the end of a section, the conveyor can be reversed at the push of a button. It is moved back a short distance, and stops automatically.



The conveyor can be reversed with just one button push. The mix return stops automatically. The conveyor can be set to idle mode just as quickly.



03 Automatic functions for material transport and distribution

These functions ensure that sufficient material for paving is automatically conveyed and spread in front of the screed. The height of the material feed is defined by a material sensor, and the automatic system ensures that it remains constant. The function is only active while paving. If the paver stops, the material feed stops.

SCREED FUNCTIONS

Function group 3

01 Compacting power

The speed of the compacting units can be set directly on the control panel. The LED scaling from 0 to 100 % indicates the set tamper bar or vibrator speed, so that adjustments can be made immediately if necessary.

02 Screed Assist (option)

This switches the Screed Assist on or off. Screed Assist is only active when the screed is in the floating position.



01 Compacting power
02 Screed Assist (option)
03 Screed settings



03 Screed settings

All key screed settings can be made on the operator's console. This includes raising or lowering the screed, extending or retracting each of the two screed sides, and adjusting the height of the tow point rams. This means the paver operator also has access to the screed at all times.

04 Idle mode

Idle mode is used to warm up or clean belt conveyors, augers and tamper bars.

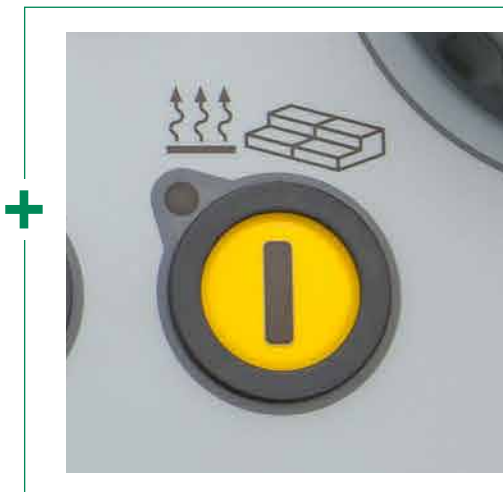

Screed heating

To optimize compaction performance and produce a neat surface texture, all compacting units are heated across the full screed width. A simple push of a button is all it takes to turn the screed heater on or off. When the screed heating is switched on, an automated check is carried out to ensure that it is functioning properly.

THE ERGOBASIC REMOTE CONTROL UNIT FOR THE SCREED

The safe and easy handling of all screed functions is crucial to high-quality asphalt paving. That's why an ErgoBasic screed remote control unit was developed specifically for the Mini Class paver operating system. Its controls are arranged logically to suit operating sequences, and their sturdy design enables them to withstand harsh jobsite conditions.

Operation is easy to understand and can be learned intuitively in a very short space of time, not least because the symbols used in the proven ErgoPlus operating system are found here, too.

The ErgoBasic screed operator's console allows all paving-related functions to be set quickly and easily. That includes direct access to the material handling systems and the sonic sensors for the augers.



01 Auger speed

In automatic mode, the maximum speed of the spreading augers can be adapted to the working width separately for the right and left by the plus and minus keys. The set value is displayed as a percentage on the LED strip.

02 Screed Float on/off

The screed can be set to the floating position at the push of a button.



03 Screed width control

The screed width on one side can be adjusted at any time by just one button push.



- 01 Setting: Auger (automatic/manual/reverse)
- 02 Screed floating on/off
- 03 Screed width control, one side
- 04 Adjustment of screed tow point cylinder

There is a remote control unit for each side of the screed. The magnetic bracket and spiral cable connection give the operator a wide range of movement. This means that he can always operate the screed from the best possible position, a factor of immense importance, particularly when working in confined spaces.

NIVELTRONIC BASIC

In line with the ErgoBasic operating concept for Mini Class pavers, VÖGELE has also developed Niveltronic Basic, a System for Automatic Grade and Slope Control. It is completely integrated into the machine control system and therefore perfectly adapted to the paver model concerned.

An outstanding aspect of Niveltronic Basic is its very intuitive user-friendliness – a feature which makes it easy even for less experienced operators to use the system correctly. This creates ideal conditions for the Mini Class pavers to work true to line and level on any base.

Each side of the screed is operated by a separate compact and highly robust Niveltronic Basic remote control unit. These are easily detachable from the magnetic brackets, and give operators a wide range of movement, so they can always position themselves optimally in any paving scenario.



01



02



03

- 01 The LED indicators attached to the sensor – so-called grade and slope control crosses – provide continuous information, clearly visible to the screed operator, on whether the set and actual values match.
- 02 A wide range of sensor types are available for the Niveltronic Basic, matching the machine's many possible applications. They extend from mechanical sensors to non-contacting sonic sensors.
- 03 The set and actual values for the grade and slope sensor can be read on the display of the Niveltronic Basic control panel.



- 01 Deviation from specified values
- 02 Setting: Sensor sensitivity
- 03 Selecting: Kind of reference (ground, tensioned wire, transverse slope)
- 04 Quick set-up
- 05 Sensor calibration

VÖGELE > GOOD TO KNOW

Available sensors

Slope sensor

The slope sensor allows the cross profile to be defined exactly and paved with complete precision. Its measuring range is +/-10 %.

Variable mechanical height sensor

The variable mechanical height sensor can be equipped with skis in lengths of 12 in. (30 cm), 39 in. (1 m) and 78 in. (2 m) for ground referencing.

Single-cell sonic sensor

The single-cell sonic sensor emits a cone of sound. This means it transmits a reference 1:1 with no averaging. It can be used for referencing in ground or stringline mode.

Multi-cell sonic sensor

The multi-cell sonic sensor, with its four sensors, is very versatile. By taking an average, it can compensate for any short unevenness in a reference.

STATE-OF-THE-ART DRIVE TECHNOLOGY

Three main components define the power unit of a SUPER 700i: its modern, liquid-cooled diesel engine, a splitter gearbox flanged directly to the engine and a large cooler assembly.

The driving force in this power pack from VÖGELE is its diesel engine of type TCD 2.9 L4. This four-cylinder engine delivers 74 hp (55.4 kW) at 2,200 rpm. Yet the fuel-saving ECO mode is sufficient for many applications. And even then, the SUPER 700i still has a full 72 hp (54 kW) at its disposal. Moreover, the machine generates even less noise when running at just 1,800 rpm.

A large cooler assembly ensures that the power unit always delivers its full output. With innovative air routing and a variable-speed fan, temperatures are continually maintained

within the optimum range, significantly extending the service life of both the diesel engine and the hydraulic oil. A further advantage is that the machine can operate without difficulty in all climate regions worldwide.

All hydraulic consumers are directly supplied with hydraulic oil via the splitter gearbox. Hydraulic pumps and valves are centrally located, making them optimally accessible for servicing.

State-of-the-art diesel engine
developing 74 hp (55.4 kW) at 2200 rpm

ECO mode at 1800 rpm
cuts fuel consumption

Large cooler assembly
for perfect cooling with low noise

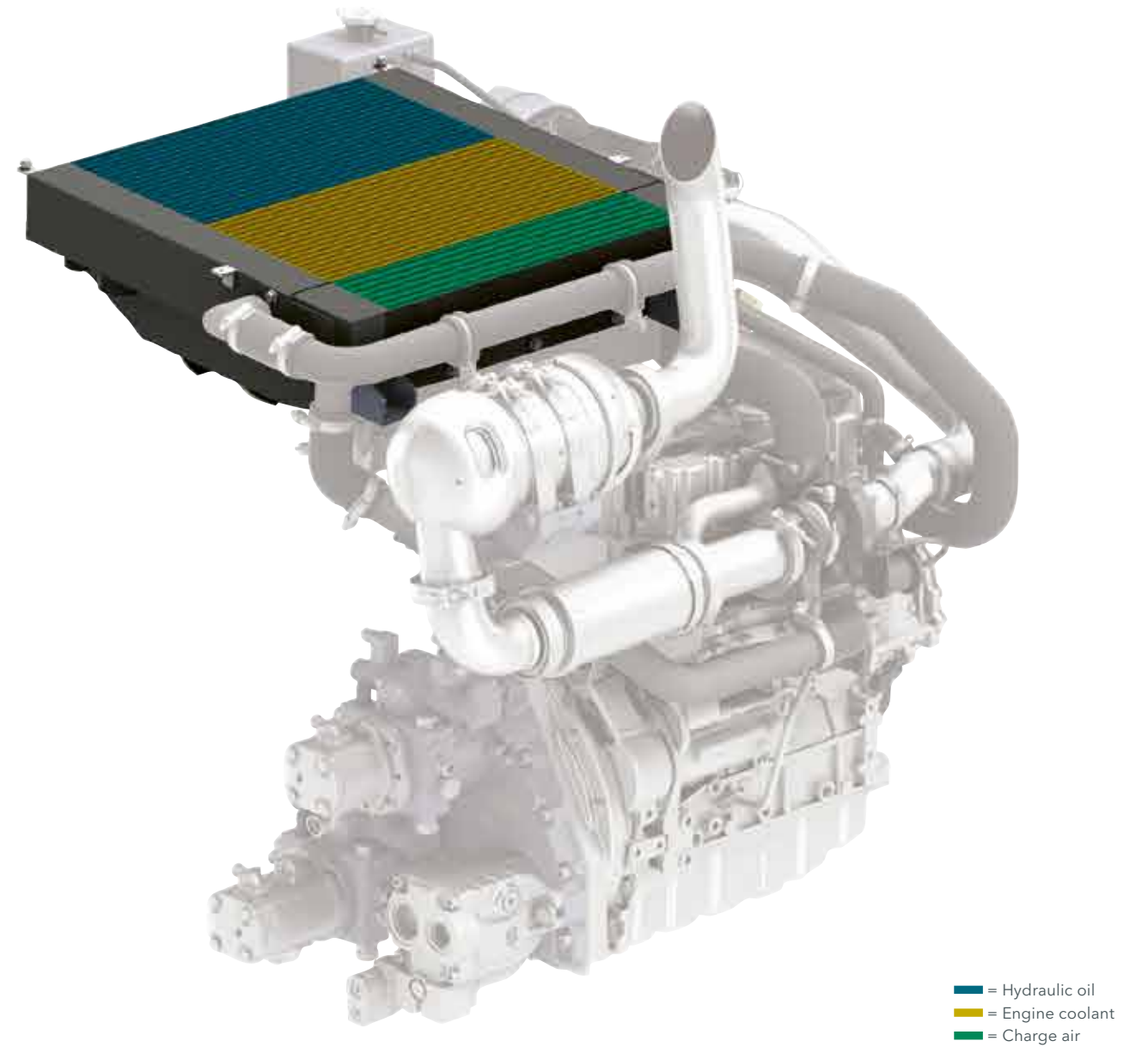

■ = Hydraulic oil
■ = Engine coolant
■ = Charge air

A large cooler assembly with innovative air routing is installed for perfect cooling of the engine coolant, hydraulic oil and charge air in all climatic zones the world over. This ensures

that the engine can deliver maximum output and helps prolong its service life.



VÖGELE > GOOD TO KNOW

Powerful diesel engine with efficient exhaust gas aftertreatment

Machines with the suffix "i" in their product designation are not only economical, but also extremely clean. The "i" stands for "intelligent emission control" and is found in the type names of all machines from the WIRTGEN GROUP equipped with the latest engine technology. Thanks to their sophisticated exhaust gas aftertreatment, these engines comply with the strict EPA and CARB standards Tier 4f.

PRECISION ON TRACKS

High-grade separate hydraulic drives are a key element of VÖGELE's unique drive concept. They enable our pavers to work highly efficiently and economically.

- > Positive tracking when moving straight and accurate cornering due to separate drive and electronic control provided for each crawler track.
- > Thanks to powerful separate drives fitted into the drive wheels for the crawler tracks, engine output is translated into paving speed with maximum efficiency.
- > Long crawler tracks with large footprints provide for maximum tractive effort, allowing the paver to get on well at a constant speed even when operating on difficult terrain.

Powerful separate drives
integrated into the crawler tracks

Positive tracking
thanks to electronically controlled separate drives



IDENTICAL SERVICE CONCEPT



The standardized service concept conceived for the VÖGELE pavers means that servicing is quick and uncomplicated. Large hinged panels provide convenient access to all service points on the machine.

All hydraulic pumps are located on the splitter gearbox and provide maximum service-friendliness thanks to their clear arrangement and easy accessibility. Wear-resistant components also guarantee a long service life.



EXTENDING SCREEDS AB 200 AND AB 220

The AB 200 and AB 220 extending screeds are specially designed for use with the SUPER 700i. They back up the particular strengths of the Mini Class paver, providing maximum flexibility while adhering to VÖGELE's special quality standards.

The AB 200 has a basic width of just 43.3 in. (1.1 m), and can be hydraulically extended to a width of 78.7 in. (2 m). It is ideally suited to paving between tracks, in milling cuts, and on narrow footpaths. For larger projects, the AB 220 is available. With a basic width of 47.2 in. (1.2 m), it can be hydraulically extended to a width of 86.6 in. (2.2 m).

The reduction system allows the pave width to be reduced continuously down to 19.7 in. (0.5 m). Once fitted, this is done very conveniently from the operator's platform, with no need for any modification. The system for paving width reduction makes backfilling trenches or asymmetric paving along a fixed edge easy, even when using bitumen tape.

Variable pave widths

from 43.3 in. (1.1 m) to 78.7 in. (2.2 m) with the AB 220

Uniform heating

of screed plates and tamper bars for homogeneous surface structures

Interval switching

supplies energy to one half of the screed heater at a time



AB 200

Paving widths

- > Infinitely variable range from 3 ft. 7 in. to 6 ft. 6 in. (1.1 m to 2 m)
- > Maximum paving width through bolt-on extensions: > 10 ft. 6 in. (2 x 24 in.) / 3.2 m (2 x 60 cm)
- > Minimum paving width of 20 in. (0.5 m) with a system for paving width reduction

Compacting system

- > AB 200 V with vibration

AB 220

Paving widths

- > Infinitely variable range from 3 ft. 11 in. to 7 ft. 3 in. (1.2 m to 2.2 m)
- > Maximum paving width through bolt-on extensions: > 10 ft. 6 in. (2 x 20 in.) / 3.2 m (2 x 50 cm)
- > Minimum paving width of 20 in. (0.5 m) with a system for paving width reduction

Compacting system

- > AB 220 V with vibration

AB 200

AB 200 V with 24 in. (60 cm) bolt-on extensions

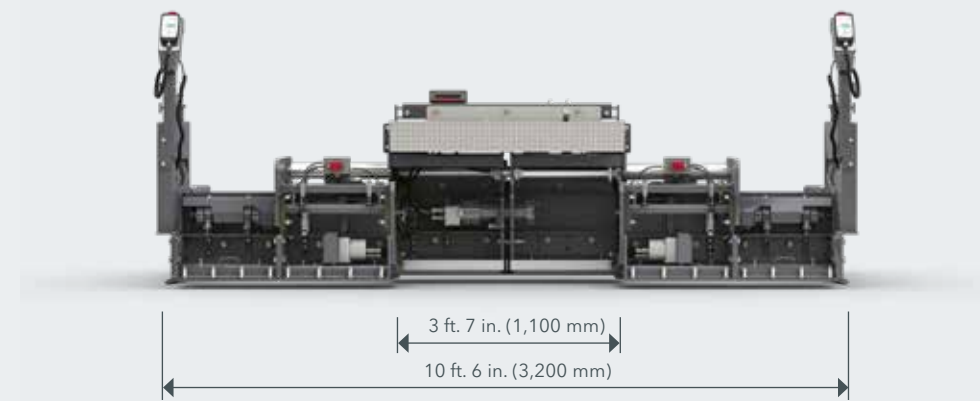

AB 220

AB 220 V with 20 in. (50 cm) bolt-on extensions

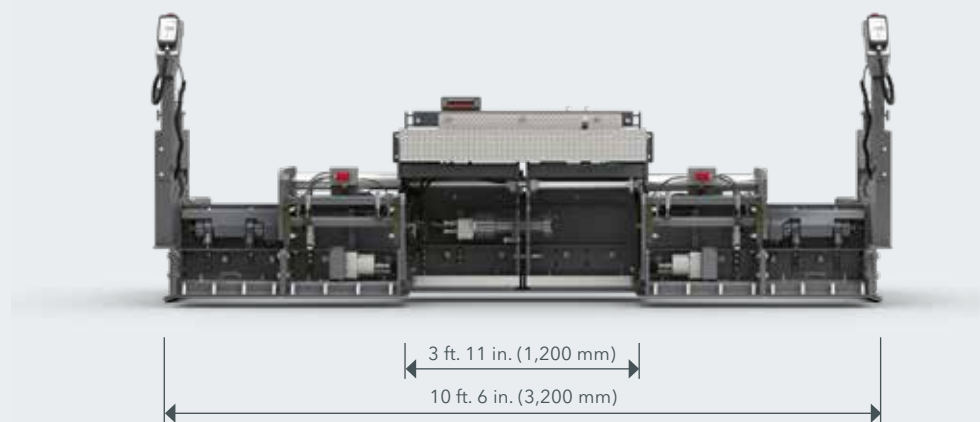

ALL THE FACTS AT A GLANCE

SUPER 700i Tracked Paver



TECHNICAL DATA

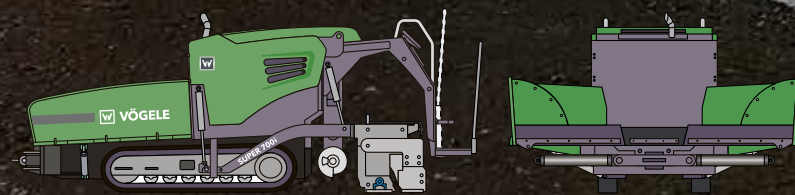

SUPER 700i

- > Paving widths 20 in. – 10 ft. 6 in. (0.5 – 3.2 m)
- > Maximum laydown rate 275 tons/h (250 tonnes/h)
- > Layer thickness up to 6 in. (15 cm)
- > Clearance width 4 ft. 7 in. (1.4 m)

YOUR WIRTGEN GROUP CUSTOMER SUPPORT

Service you can rely on.

Trust in our quick, reliable support over the entire lifetime of your machine. Our wide-ranging service portfolio offers the right solution for any challenge you face.



Service

We deliver on our service promise – with quick, uncomplicated help, whether on-site or at our professional workshops. Our service team are all expertly trained. They are able to carry out repairs and care and maintenance work quickly using special tools. We can also provide you with service agreements tailored to your needs if you wish.

> www.wirtgen-group.com/service



Spare parts

WIRTGEN GROUP original parts and accessories will assure the high reliability and availability of your machines over the long term. Our experts will also be happy to advise you on application-optimized solutions for wearing parts. Our parts are available worldwide at any time, and easy to order.

> parts.wirtgen-group.com



Training

The WIRTGEN GROUP's product brands are specialists in their field, and have decades of application experience. Our customers benefit from that expertise too. We will be glad to pass on our knowledge to you at our WIRTGEN GROUP training courses, tailored to the needs of operators and service personnel.

> www.wirtgen-group.com/training



Telematics solutions

Construction machines with leading technology and perfected telematics solutions work hand-in-hand in the WIRTGEN GROUP. The Operations Center* – the platform for digital solutions for process, machine and service optimization – allows you not only to simplify maintenance planning for your machines but also to increase your productivity and cost-effectiveness.

> www.wirtgen-group.com/telematics



Wirtgen America, Inc.

6030 Dana Way
Antioch, TN 37013
USA

T: +1 615 501-0600

F: +1 615 501-0691

M: info.america@wirtgen-group.com

 www.wirtgen-group.com/america



Scan the code for more information.